

# ACE

## SLAB Damping Plates

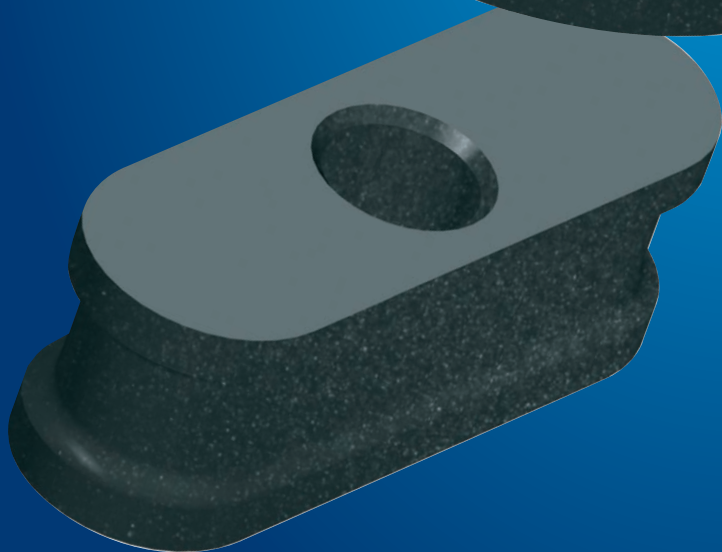

**Special Catalogue**  
**Edition 4.2007**

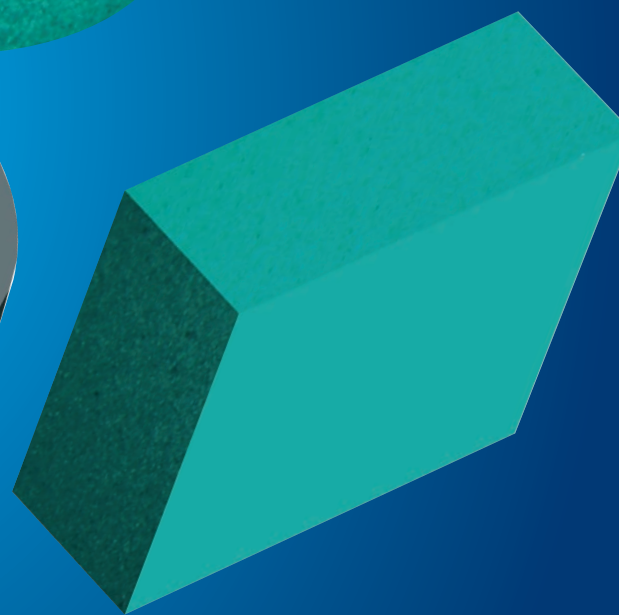
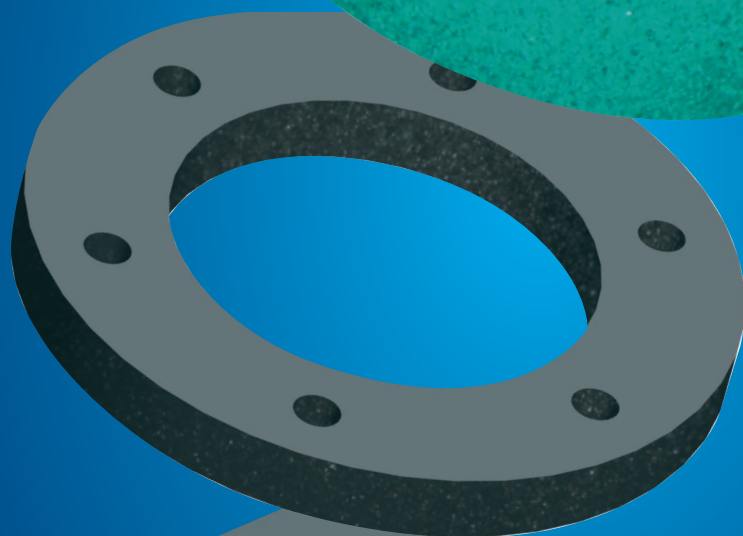
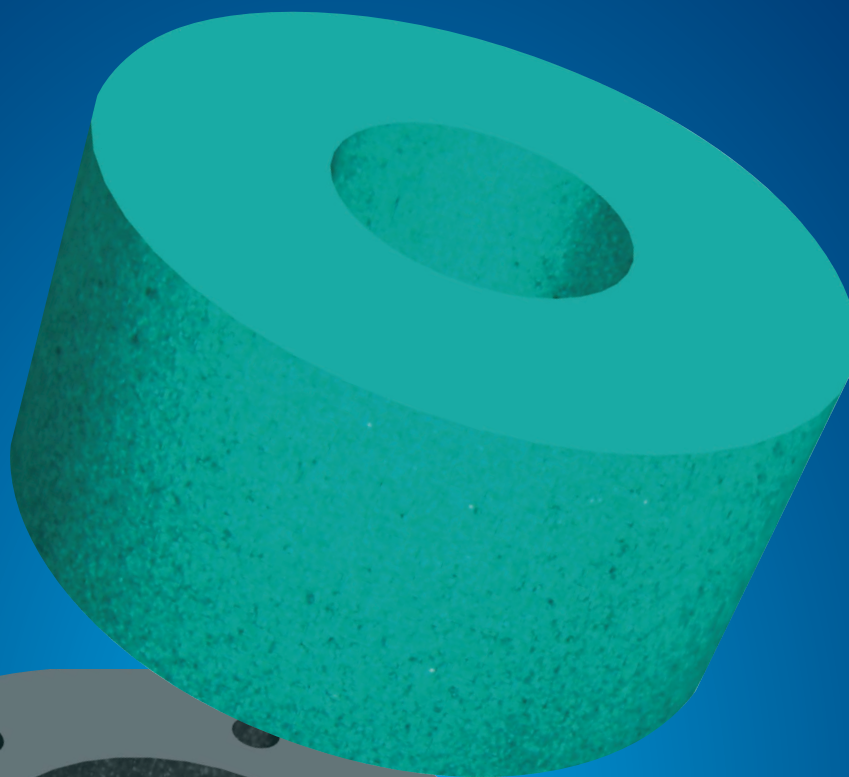

### Dear Reader,

When we hear the term visco-elastic PUR damping materials, we usually think about insulation or the reduction of vibrations.

ACE has new advanced PUR damping materials for shock absorption and offers customers new possibilities in regard to the many fold applications. ACE-SLAB offers the ideal solution for large area damping requirements in the form of plates or to customers specific requirements. Mounting is done by simply bonding the material to the individual surfaces.

Alongside this innovative D-series for damping, solutions for the traditional reduction of vibrations are offered with the F-series (spring). This high-tech material made of microcellular polyurethane elastomers is foamed with water in an environmentally safe manner. Its homogeneous structure flows throughout the product producing repeatable damping capabilities in plate thicknesses of up to 80 mm.

In addition to maximum plate sizes of 1.5 m wide and 5 m long, other geometric shapes can be manufactured with three-dimensional forms. PUR damping plates can easily be bonded to other materials, self-adhesive backing films or wearing surfaces, thus allowing mounting in even the most difficult of applications as well as using it in the food industry or for noise reduction.

The added value lies especially in the innovative and exceptionally broad versatility of this new material that is manufactured using a patented formula.

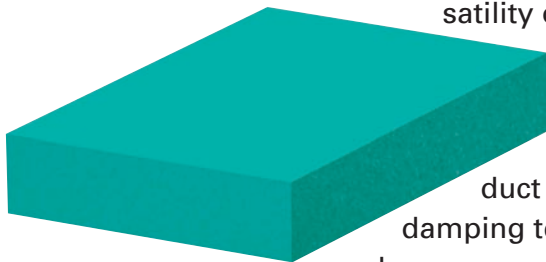

With this special catalogue, ACE faces up to the challenges of damping technology and enhances the existing product range. Further information into ACE's world of industrial damping technology can be found in the current main catalogue or our homepage at [www.acecontrols-int.com](http://www.acecontrols-int.com). There, you can find industrial shock absorbers in the sizes M6 to M130, safety shock absorbers, profile dampers, linear and rotary dampers as well as gas springs.



#### Key to symbols used

$W_1$	Kinetic energy per cycle	Nm
$W_2$	Propelling force energy per cycle	Nm
$W_3$	Total energy per cycle ( $W_1 + W_2$ )	Nm
$m$	Mass to be decelerated	kg
$v$	Velocity of moving mass	m/s
$v_D$	Impact velocity at damping element	m/s
$\omega$	Angular velocity	rads/s
$F$	Propelling force	N
$M$	Propelling torque	Nm
$I$	Moment of Inertia	kgm <sup>2</sup>
$g$	Acceleration due to gravity = 9.81	m/s <sup>2</sup>
$h$	Drop height excl. stroke of damping element	m
$s$	Stroke of damping element	m
$L/R/r$	Radius	m
$\mu$	Coefficient of friction	°
$\beta$	Angle of incline	°

#### Calculation example case 2

$m = 20.6 \text{ kg}$   
 $v = 1 \text{ m/s}$   
 $F = 200 \text{ N}$   
 $s = 0.006 \text{ m}$  (= 6 mm desired stroke)

$$\begin{aligned}
 W_1 &= m \cdot v^2 \cdot 0.5 = 20.6 \text{ kg} \cdot 1 \text{ m/s}^2 \cdot 0.5 = 10.3 \text{ Nm} \\
 W_2 &= F \cdot s = 200 \text{ N} \cdot 0.006 \text{ m} = 1.2 \text{ Nm} \\
 W_3 &= W_1 + W_2 = 10.3 \text{ Nm} + 1.2 \text{ Nm} = 11.5 \text{ Nm}
 \end{aligned}$$

Chosen damping plate: SL-030-25-Dxxxx (see page 7)

Dimensions: 100 x 100 x 25 mm

Stroke utilization: ≈ 6 mm

#### Cycle rate:

The maximum cycle rate mainly depends on the return time of the chosen damping plate.

For approximate return time see capacity charts on page 6 to 11.

#### 1 Mass without propelling force

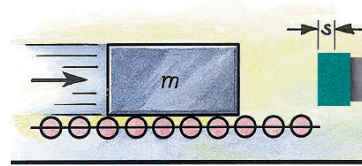

#### Formulae

$$\begin{aligned}
 W_1 &= m \cdot v^2 \cdot 0.5 \\
 W_2 &= 0 \\
 W_3 &= W_1 + W_2 \\
 W_4 &= W_3 \cdot x \\
 v_D &= v
 \end{aligned}$$

#### 2 Mass with propelling force

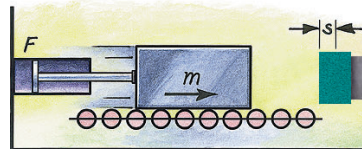

#### Formulae

$$\begin{aligned}
 W_1 &= m \cdot v^2 \cdot 0.5 \\
 W_2 &= F \cdot s \\
 W_3 &= W_1 + W_2 \\
 W_4 &= W_3 \cdot x \\
 v_D &= v
 \end{aligned}$$

2.1 for vertical motion upwards

2.2 for vertical motion downwards

$$\begin{aligned}
 W_2 &= (F - m \cdot g) \cdot s \\
 W_2 &= (F + m \cdot g) \cdot s
 \end{aligned}$$

#### 4 Mass on driven rollers

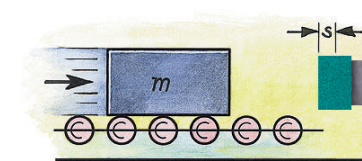

#### Formulae

$$\begin{aligned}
 W_1 &= m \cdot v^2 \cdot 0.5 \\
 W_2 &= m \cdot \mu \cdot g \cdot s \\
 W_3 &= W_1 + W_2 \\
 W_4 &= W_3 \cdot x \\
 v_D &= v
 \end{aligned}$$

#### 5 Swinging mass with propelling torque

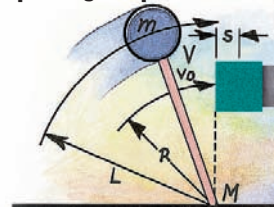

#### Formulae

$$\begin{aligned}
 W_1 &= m \cdot v^2 \cdot 0.5 = 0.5 \cdot J \cdot \omega^2 \\
 W_2 &= \frac{M \cdot s}{R} \\
 W_3 &= W_1 + W_2 \\
 W_4 &= W_3 \cdot x \\
 v_D &= \frac{v \cdot R}{L} = \omega \cdot R
 \end{aligned}$$

#### 6 Free falling mass

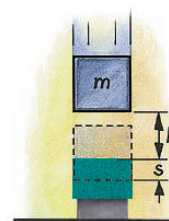

#### Formulae

$$\begin{aligned}
 W_1 &= m \cdot g \cdot h \\
 W_2 &= m \cdot g \cdot s \\
 W_3 &= W_1 + W_2 \\
 W_4 &= W_3 \cdot x \\
 v_D &= \sqrt{2 \cdot g \cdot h}
 \end{aligned}$$

#### 6.1 Mass rolling/sliding down incline

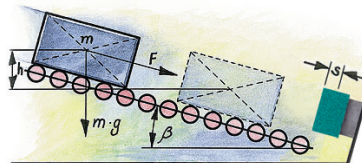

#### Formulae

$$\begin{aligned}
 W_1 &= m \cdot g \cdot h = m \cdot v_D^2 \cdot 0.5 \\
 W_2 &= m \cdot g \cdot \sin \beta \cdot s \\
 W_3 &= W_1 + W_2 \\
 W_4 &= W_3 \cdot x \\
 v_D &= \sqrt{2 \cdot g \cdot h}
 \end{aligned}$$

6.1 a propelling force up incline

6.1 b propelling force down incline

$$\begin{aligned}
 W_2 &= (F - m \cdot g \cdot \sin \beta) \cdot s \\
 W_2 &= (F + m \cdot g \cdot \sin \beta) \cdot s
 \end{aligned}$$

#### 6.2 Mass free falling about a pivot point

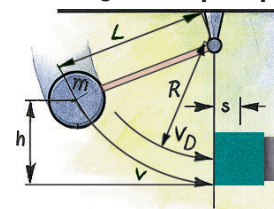

Calculation as per example 6.1 except  $W_2 = 0$   
 $W_1 = m \cdot g \cdot h$

$$v_D = \sqrt{2 \cdot g \cdot h} \cdot \frac{R}{L}$$

SLAB damping plates of the SL-030, SL-100 and SL-300 series are visco-elastic PUR materials that are manufactured according to a patented formula and which were especially designed to absorb shock loads. At the same time, the resulting structure-borne noise is effectively reduced.

This material is characterized by its very high inner damping. The rebound elasticity is around < 30% (Tolerance +/-10%) following DIN 53573.

The result makes this product an alternative to hydraulic end-of-travel damping, if the load doesn't need to be stopped accurately and the energy doesn't have to be reduced by 100%.

The densities of SL-030 = 270 kg/m<sup>3</sup>, SL-100 = 500 kg/m<sup>3</sup> and SL-300 = 800 kg/m<sup>3</sup> cover a wide spectrum of the energy absorption to the applied area. This enables a relatively independent choice of applied area.

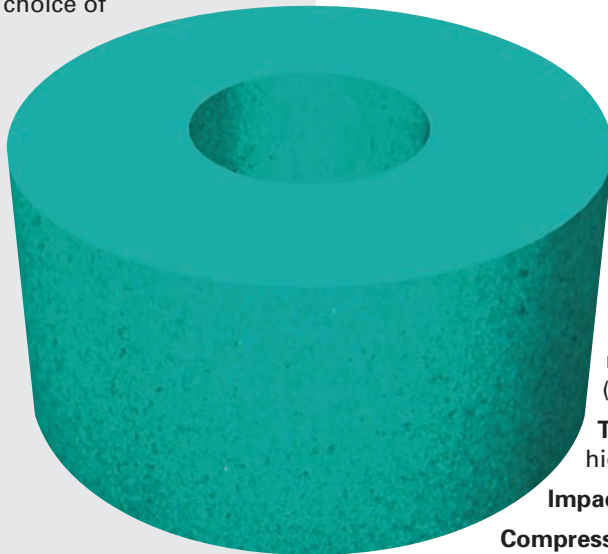
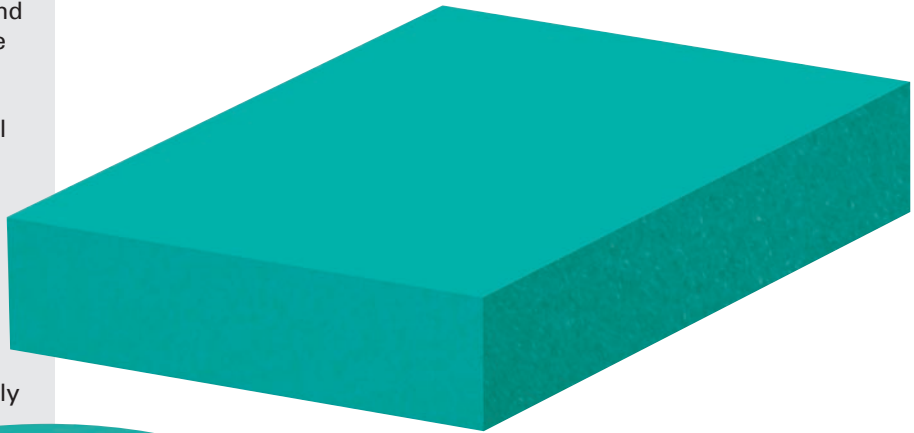

**Environment:** resistant against ozone and UV radiation; food-graded according to ENV 1186-3 (also see chemical resistancy pg.18)

**Temperature range:** -30°C to +70°C, short-term higher temperature potential up to 110°C

**Impact velocity range:** max. 5 m/s

**Compression set:** ≤5%, at 50% of compression, 23°C, 70 h, 30 min after unloading, according to EN ISO 1856

**Fire rating:** B2, normally flammable according to DIN 4102

**Standard density:** 270 kg/m<sup>3</sup>, 500 kg/m<sup>3</sup> and 800 kg/m<sup>3</sup>

**Impact resilience:** < 30%, tolerance +/- 10%, according to DIN 53573

**On request:** available with compact polyurethane wearing surface, shore hardness: 82 shore Sh A

**Possibilities for cutting:** water jet cutting, stamping, splitting, sawing, drilling, etc.

**Mounting style:** Bonding (see adhesive recommendation page 17), clamps, screws, etc.

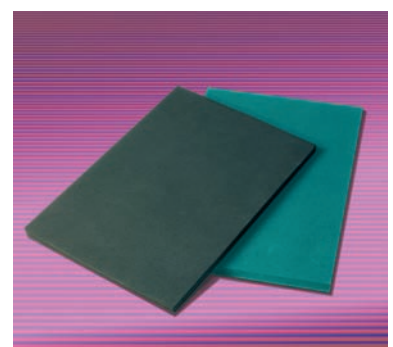

These data are based on the current standard of knowledge. They can be taken as calculation or reference values and are subject to the usual manufacturing tolerances; subject to change.

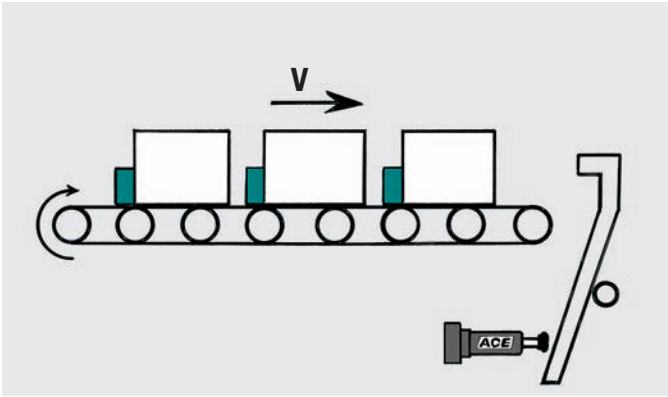

Damping in between Pallets

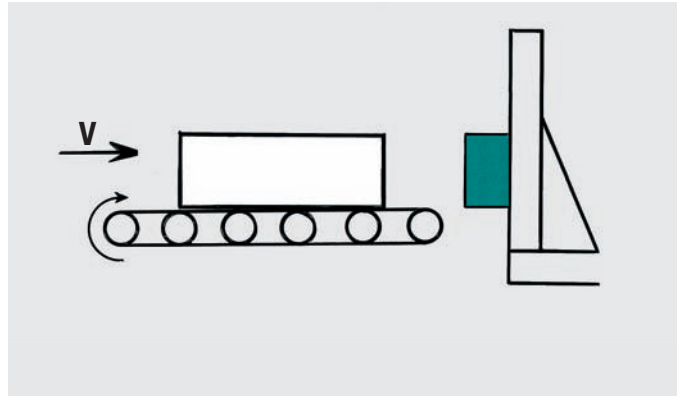

Impact Buffer for Slats, Beams, etc.

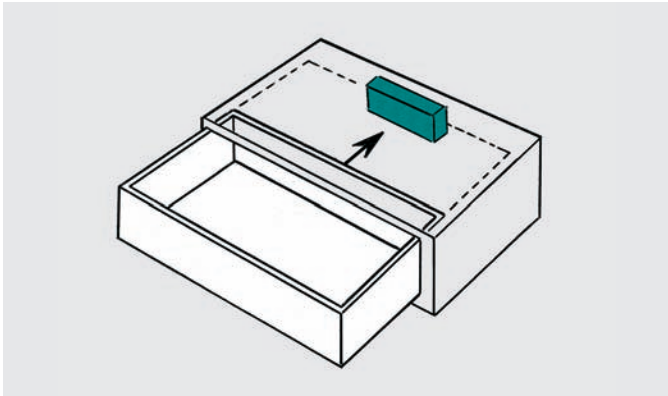

Drawer Damping

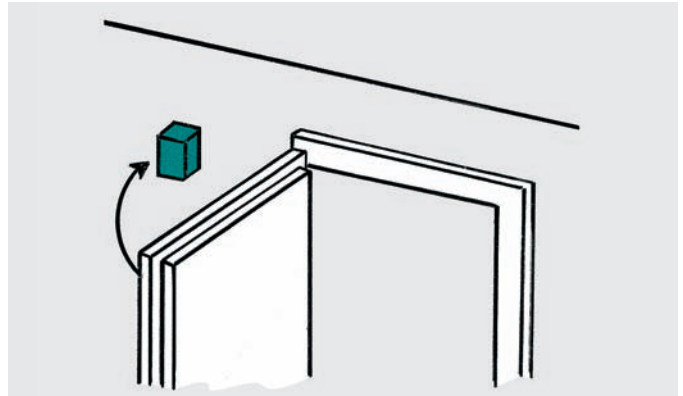

Door Stopper, i.e., for Glass Doors

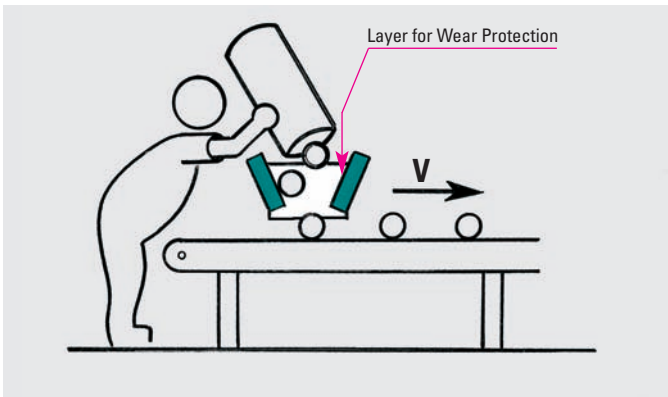

Funnel Tube Lining at Assembly Lines

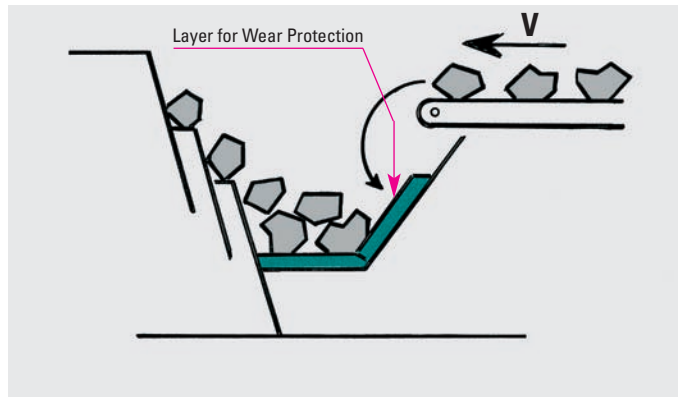

Feed Hopper Lining at Graded Sorter

#### Ordering Example

ACE-SLAB \_\_\_\_\_  
 Material Type \_\_\_\_\_  
 Material Thickness \_\_\_\_\_  
 Dimension/Shape \_\_\_\_\_  
 (is assigned by ACE)

SL-030-12-Dxxxx

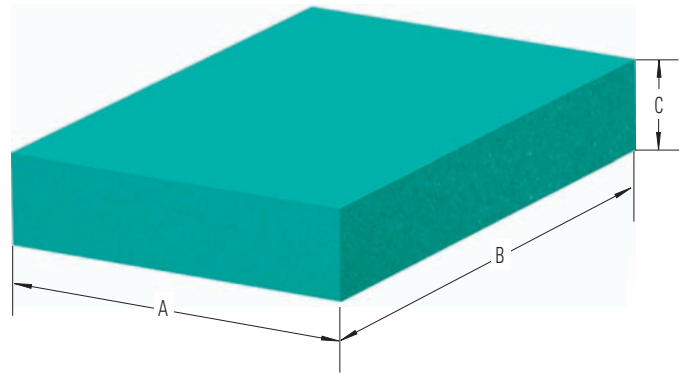

#### Technical Data

**Material:** mixed cellular polyether urethane  
**Characteristics:** visco-elastic PUR material with high damping capability  
**Standard Colour:** green  
**Delivery Form:** thickness 12 mm, rolls: 1.5 m wide, 5.0 m long, strips: up to the maximum width and length

Other dimensions (also thickness), colours, shapes and cut-out parts on request.

The chosen damping plate should be tested by the customer on the specific application.

#### Dimensions and Capacity Chart

Material Type	W <sub>3</sub> max.* Nm/stroke	Stroke Utilization* mm	A mm	B mm	C mm	Area mm <sup>2</sup>	Density kg/m <sup>3</sup>	Return Time sec.	Weight g
SL-030-12-Dxxxx	2.3 (5.0)	3 (6)	50	50	12	2 500	270	approx. 3 (4)	approx. 8
SL-030-12-Dxxxx	4.3 (9.5)	3 (6)	70.7	70.7	12	5 000	270	approx. 3 (4)	approx. 17
SL-030-12-Dxxxx	9.5 (19.5)	3 (6)	100	100	12	10 000	270	approx. 3 (4)	approx. 34

\* Energy absorption and stroke utilization as well as the below illustrated dynamic curve progression refer to a calculated free falling mass with an impact velocity of 1 m/s. For differing application data, these values can only be used as a reference. The energy absorption depends on the **individual impact surface** and stroke utilization. The longer the load duration the more the reduction in energy absorption (material fatigue).

SL set 1.1 includes the 3 above mentioned sample plates. For other dimensions see page 20.

#### Damping Characteristics SL-030-12

Force-Stroke static, Stroke Utilization 3 mm, 25%

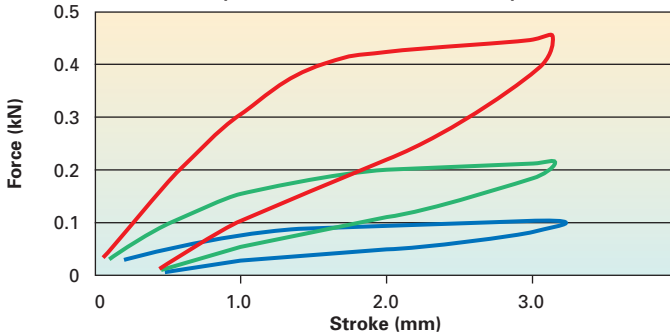

Force-Stroke dynamic, Stroke Utilization 3 mm, 25%

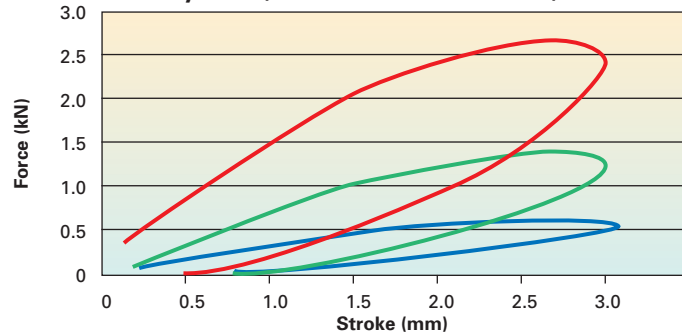

Force-Stroke static, Stroke Utilization 6 mm, 50%

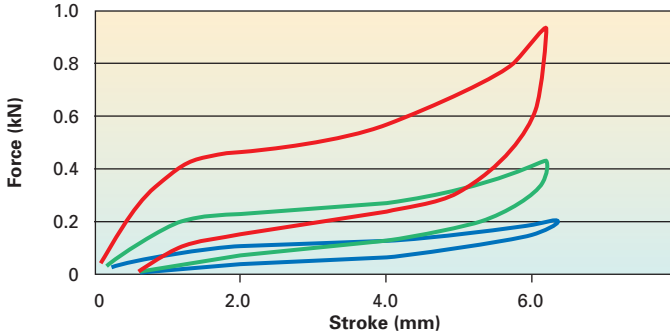

Force-Stroke dynamic, Stroke Utilization 6 mm, 50%

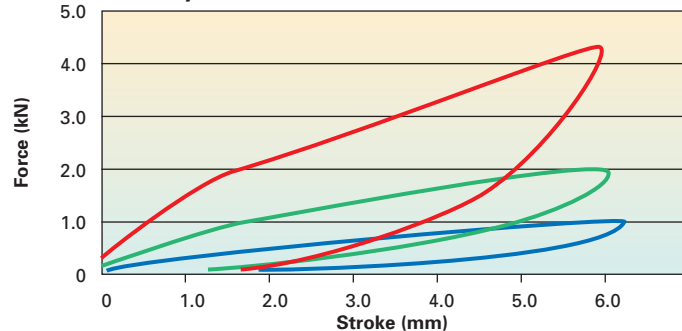

Load data: static, between two level plates,  
 Deformation velocity 1% of the plate thickness / sec.

— Area 10 000 mm<sup>2</sup>  
 — Area 5 000 mm<sup>2</sup>  
 — Area 2 500 mm<sup>2</sup>

Load data: dynamic, free-falling mass,  
 Impact velocity about 1 m/s.

#### Ordering Example

ACE-SLAB \_\_\_\_\_  
 Material Type \_\_\_\_\_  
 Material Thickness \_\_\_\_\_  
 Dimension/Shape \_\_\_\_\_  
 (is assigned by ACE)

SL-030-25-Dxxxx

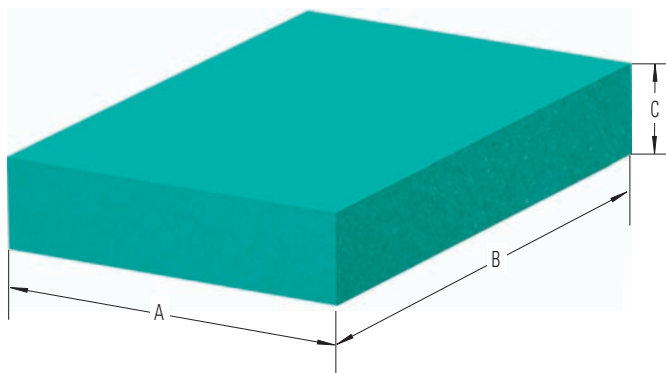

#### Technical Data

**Material:** mixed cellular polyether urethane  
**Characteristics:** viscoelastic PUR material with high damping capability  
**Standard Colour:** green  
**Delivery Form:** thickness 25 mm, rolls: 1.5 m wide, 5.0 m long, strips: up to the maximum width and length

Other dimensions (also thickness), colours, shapes and cut-out parts on request.

The chosen damping plate should be tested by the customer on the specific application.

#### Dimensions and Capacity Chart

Material Type	W <sub>3</sub> max.* Nm/stroke	Stroke Utilization* mm	A mm	B mm	C mm	Area mm <sup>2</sup>	Density kg/m <sup>3</sup>	Return Time sec.	Weight g
SL-030-25-Dxxxx	3.5 (6.0)	6 (12)	50	50	25	2 500	270	approx. 4 (5)	approx. 17
SL-030-25-Dxxxx	5.7 (11.5)	6 (12)	70.7	70.7	25	5 000	270	approx. 4 (5)	approx. 34
SL-030-25-Dxxxx	11.5 (21.5)	6 (12)	100	100	25	10 000	270	approx. 4 (5)	approx. 68

\* Energy absorption and stroke utilization as well as the below illustrated dynamic curve progression refer to a calculated free falling mass with an impact velocity of 1 m/s. For differing application data, these values can only be used as a reference. The energy absorption depends on the individual impact surface and stroke utilization. The longer the load duration the more the reduction in energy absorption (material fatigue).

SL set 1.2 includes the 3 above mentioned sample plates. For other dimensions see page 20.

#### Damping Characteristics SL-030-25

Force-Stroke static, Stroke Utilization 6 mm, 25%

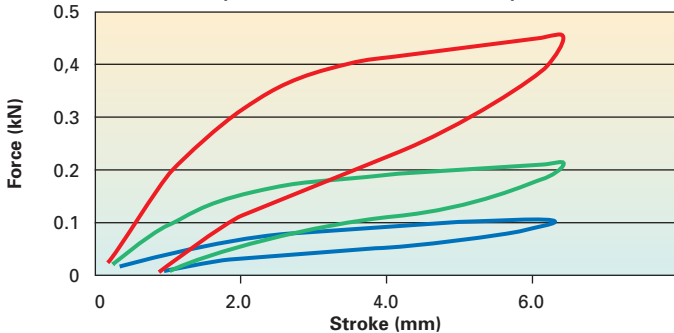

Force-Stroke dynamic, Stroke Utilization 6 mm, 25%

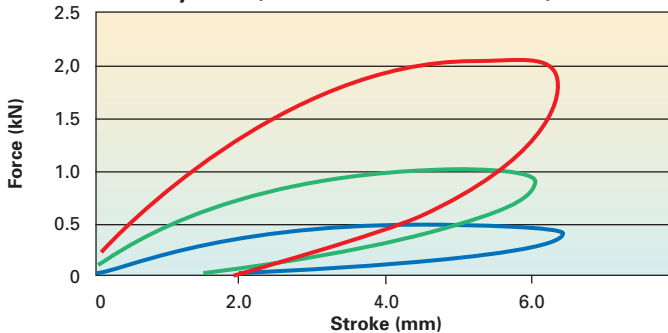

Force-Stroke static, Stroke Utilization 12 mm, 50%

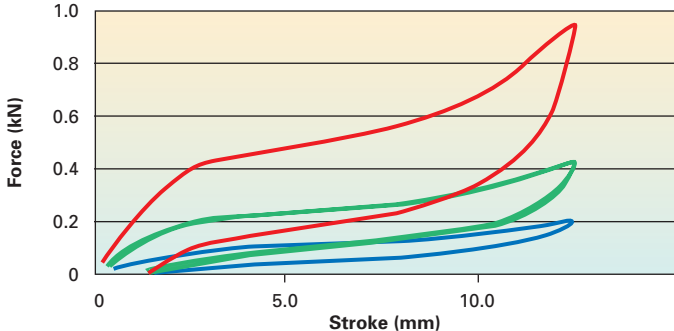

Force-Stroke dynamic, Stroke Utilization 12 mm, 50%

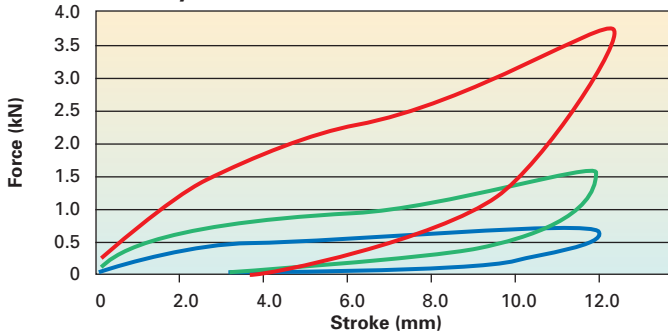

Load data: static, between two level plates,  
 Deformation velocity 1% of the plate thickness / sec.

— Area 10 000 mm<sup>2</sup>  
 — Area 5 000 mm<sup>2</sup>  
 — Area 2 500 mm<sup>2</sup>

Load data: dynamic, free-falling mass,  
 Impact velocity about 1 m/s.

Issue 4.2007 Specifications subject to change

#### Ordering Example

ACE-SLAB \_\_\_\_\_  
 Material Type \_\_\_\_\_  
 Material Thickness \_\_\_\_\_  
 Dimension/Shape \_\_\_\_\_  
 (is assigned by ACE)

SL-100-12-Dxxxx

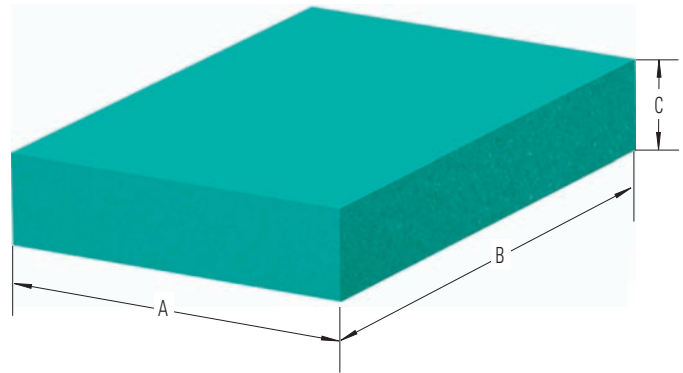

#### Technical Data

**Material:** mixed cellular polyether urethane  
**Characteristics:** viscoelastic PUR material with high damping capability  
**Standard Colour:** green  
**Delivery Form:** thickness 12 mm, rolls: 1.5 m wide, 5.0 m long, strips: up to the maximum width and length

Other dimensions (also thickness), colours, shapes and cut-out parts on request.

The chosen damping plate should be tested by the customer on the specific application.

#### Dimensions and Capacity Chart

Material Type	W <sub>3</sub> max.* Nm/stroke	Stroke Utilization* mm	A mm	B mm	C mm	Area mm <sup>2</sup>	Density kg/m <sup>3</sup>	Return Time sec.	Weight g
SL-100-12-Dxxxx	4.5 (13.0)	3 (6)	50	50	12	2 500	500	approx. 3 (4)	approx. 16
SL-100-12-Dxxxx	11.5 (29.0)	3 (6)	70.7	70.7	12	5 000	500	approx. 3 (4)	approx. 31
SL-100-12-Dxxxx	23.0 (75.0)	3 (6)	100	100	12	10 000	500	approx. 3 (4)	approx. 63

\* Energy absorption and stroke utilization as well as the below illustrated dynamic curve progression refer to a calculated free falling mass with an impact velocity of 1 m/s. For differing application data, these values can only be used as a reference. The energy absorption depends on the **individual impact surface** and stroke utilization. The longer the load duration the more the reduction in energy absorption (material fatigue).

SL set 1.3 includes the 3 above mentioned sample plates. For other dimensions see page 20.

#### Damping Characteristics SL-100-12

Force-Stroke static, Stroke Utilization 3 mm, 25%

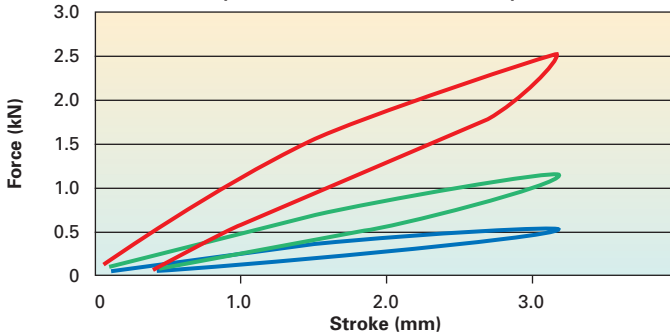

Force-Stroke dynamic, Stroke Utilization 3 mm, 25%

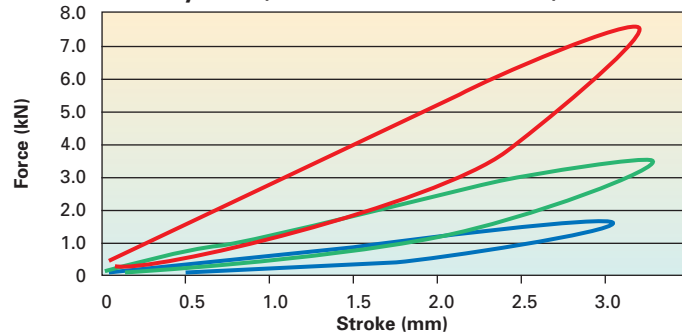

Force-Stroke static, Stroke Utilization 6 mm, 50%

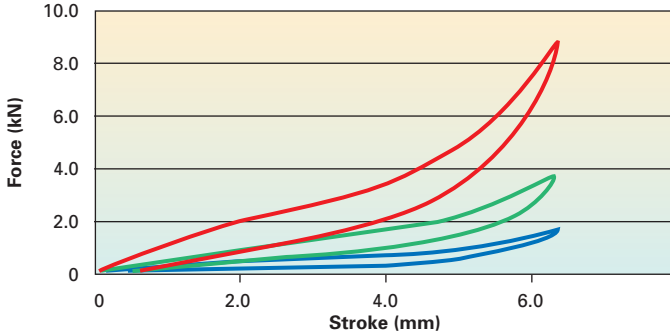

Force-Stroke dynamic, Stroke Utilization 6 mm, 50%

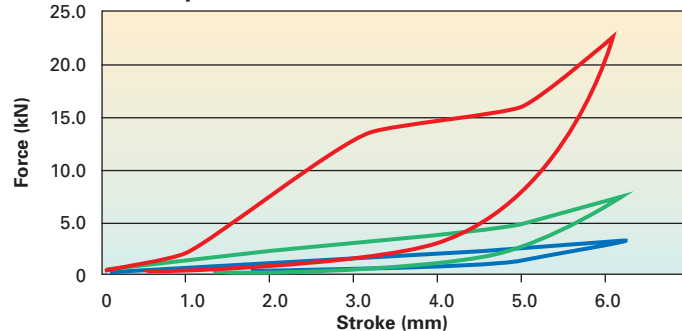

Load data: static, between two level plates,  
 Deformation velocity 1% of the plate thickness / sec.

— Area 10 000 mm<sup>2</sup>  
 — Area 5 000 mm<sup>2</sup>  
 — Area 2 500 mm<sup>2</sup>

Load data: dynamic, free-falling mass,  
 Impact velocity about 1 m/s.

#### Ordering Example

ACE-SLAB \_\_\_\_\_  
 Material Type \_\_\_\_\_  
 Material Thickness \_\_\_\_\_  
 Dimension/Shape \_\_\_\_\_  
 (is assigned by ACE)

SL-100-25-Dxxxx

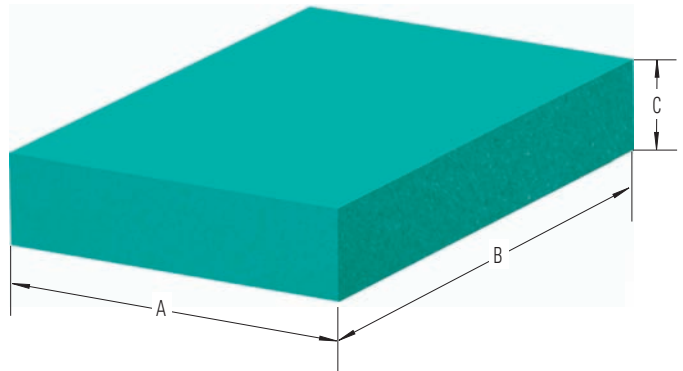

#### Technical Data

**Material:** mixed cellular polyether urethane  
**Characteristics:** viscoelastic PUR material with high damping capability  
**Standard Colour:** green  
**Delivery Form:** thickness 25 mm, rolls: 1.5 m wide, 5.0 m long, strips: up to the maximum width and length

Other dimensions (also thickness), colours, shapes and cut-out parts on request.

The chosen damping plate should be tested by the customer on the specific application.

#### Dimensions and Capacity Chart

Material Type	W <sub>3</sub> max.* Nm/stroke	Stroke Utilization* mm	A mm	B mm	C mm	Area mm <sup>2</sup>	Density kg/m <sup>3</sup>	Return Time sec.	Weight g
SL-100-25-Dxxxx	5.7 (14.5)	6 (12)	50	50	25	2 500	500	approx. 4 (5)	approx. 31
SL-100-25-Dxxxx	11.5 (33.0)	6 (12)	70.7	70.7	25	5 000	500	approx. 4 (5)	approx. 62
SL-100-25-Dxxxx	28.5 (90.0)	6 (12)	100	100	25	10 000	500	approx. 4 (5)	approx. 125

\* Energy absorption and stroke utilization as well as the below illustrated dynamic curve progression refer to a calculated free falling mass with an impact velocity of 1 m/s. For differing application data, these values can only be used as a reference. The energy absorption depends on the individual impact surface and stroke utilization. The longer the load duration the more the reduction in energy absorption (material fatigue).

SL set 1.4 includes the 3 above mentioned sample plates. For other dimensions see page 20.

#### Damping Characteristics SL-100-25

Force-Stroke static, Stroke Utilization 6 mm, 25%

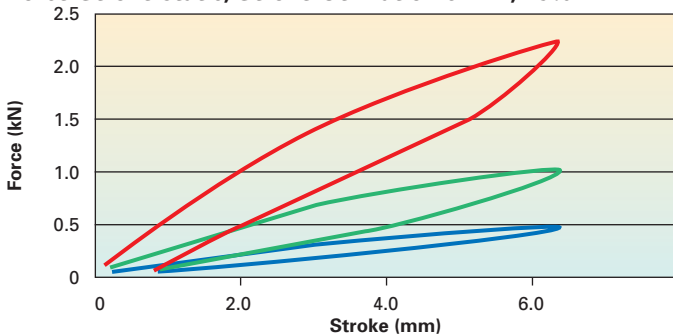

Force-Stroke dynamic, Stroke Utilization 6 mm, 25%

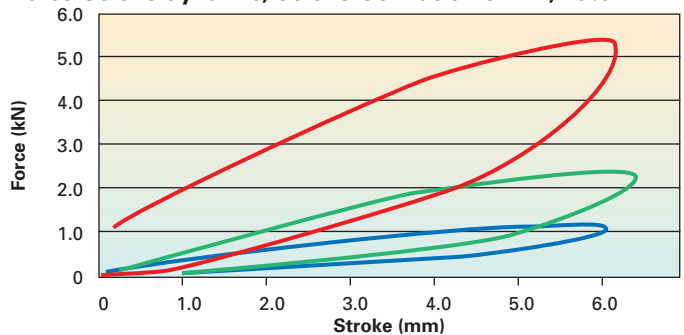

Force-Stroke static, Stroke Utilization 12 mm, 50%

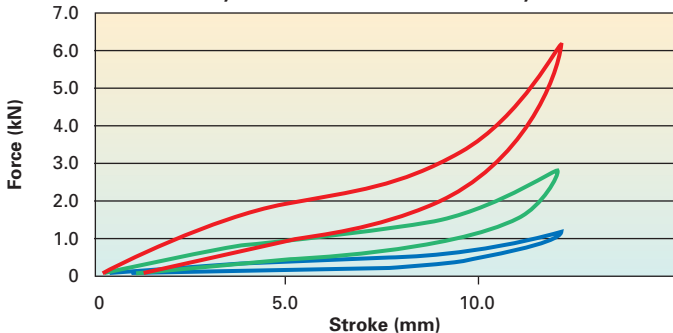

Force-Stroke dynamic, Stroke Utilization 12 mm, 50%

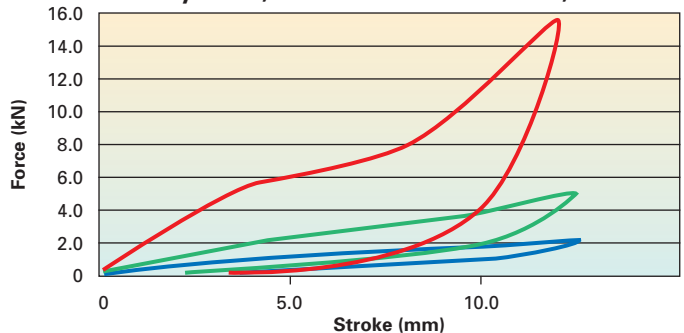

Load data: static, between two level plates,  
 Deformation velocity 1% of the plate thickness / sec.

— Area 10 000 mm<sup>2</sup>  
 — Area 5 000 mm<sup>2</sup>  
 — Area 2 500 mm<sup>2</sup>

Load data: dynamic, free-falling mass,  
 Impact velocity about 1 m/s.

#### Ordering Example

ACE-SLAB \_\_\_\_\_  
 Material Type \_\_\_\_\_  
 Material Thickness \_\_\_\_\_  
 Dimension/Shape \_\_\_\_\_  
 (is assigned by ACE)

SL-300-12-Dxxxx

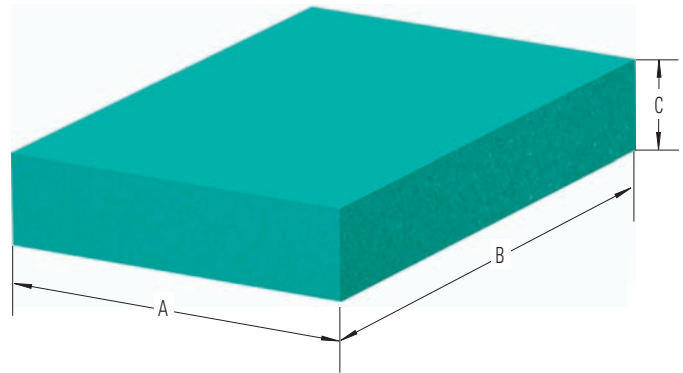

#### Technical Data

**Material:** mixed cellular polyether urethane  
**Characteristics:** viscoelastic PUR material with high damping capability  
**Standard Colour:** green  
**Delivery Form:** thickness 12 mm, rolls: 1.5 m wide, 5.0 m long, strips: up to the maximum width and length

Other dimensions (also thickness), colours, shapes and cut-out parts on request.

The chosen damping plate should be tested by the customer on the specific application.

#### Dimensions and Capacity Chart

Material Type	W <sub>3</sub> max.* Nm/stroke	Stroke Utilization* mm	A mm	B mm	C mm	Area mm <sup>2</sup>	Density kg/m <sup>3</sup>	Return Time sec.	Weight g
SL-300-12-Dxxxx	17.0 (85.0)	3 (6)	50	50	12	2 500	800	approx. 2 (3)	approx. 25
SL-300-12-Dxxxx	50.0 (250.0)	3 (6)	70.7	70.7	12	5 000	800	approx. 2 (3)	approx. 50
SL-300-12-Dxxxx	100.0	3 (6)	100	100	12	10 000	800	approx. 2 (3)	approx. 100

\* Energy absorption and stroke utilization as well as the below illustrated dynamic curve progression refer to a calculated free falling mass with an impact velocity of 1 m/s. For differing application data, these values can only be used as a reference. The energy absorption depends on the **individual impact surface** and stroke utilization. The longer the load duration the more the reduction in energy absorption (material fatigue).

SL set 1.5 includes the 3 above mentioned sample plates. For other dimensions see page 20.

#### Damping Characteristics SL-300-12

Force-Stroke static, Stroke Utilization 3 mm, 25%

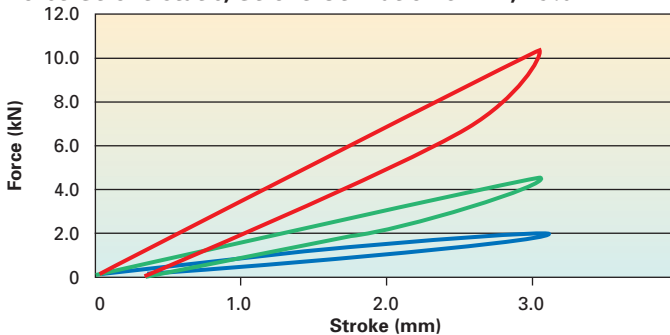

Force-Stroke dynamic, Stroke Utilization 3 mm, 25%

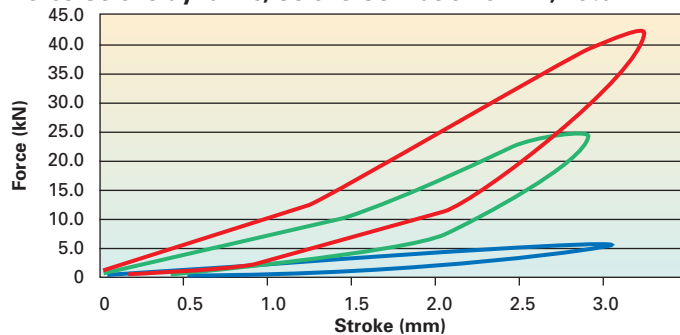

Force-Stroke static, Stroke Utilization 6 mm, 50%

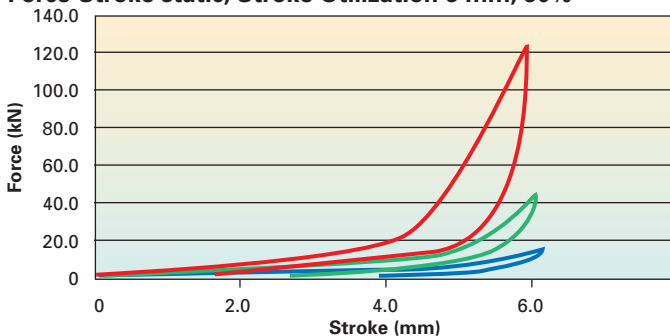

Force-Stroke dynamic, Stroke Utilization 6 mm, 50%

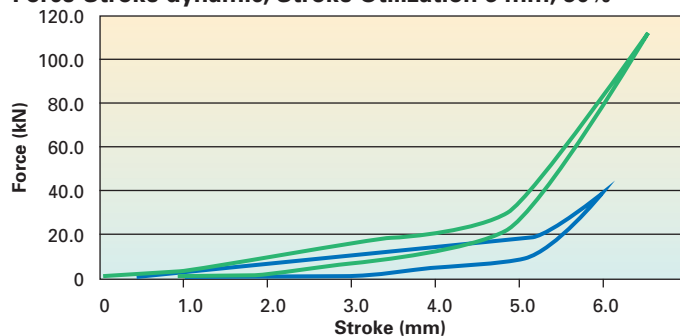

Load data: static, between two level plates,  
 Deformation velocity 1% of the plate thickness / sec.

— Area 10 000 mm<sup>2</sup>  
 — Area 5 000 mm<sup>2</sup>  
 — Area 2 500 mm<sup>2</sup>

Load data: dynamic, free-falling mass,  
 Impact velocity about 1 m/s.

#### Ordering Example

ACE-SLAB \_\_\_\_\_  
 Material Type \_\_\_\_\_  
 Material Thickness \_\_\_\_\_  
 Dimension/Shape \_\_\_\_\_  
 (is assigned by ACE)

SL-300-25-Dxxxx

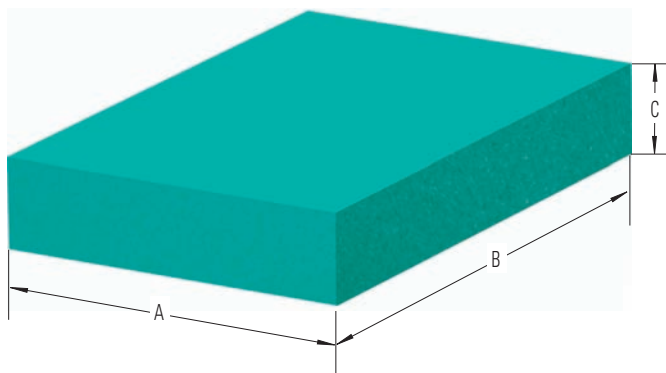

#### Technical Data

**Material:** mixed cellular polyether urethane  
**Characteristics:** viscoelastic PUR material with high damping capability  
**Standard Colour:** green  
**Delivery Form:** thickness 25 mm, rolls: 1.5 m wide, 5.0 m long, strips: up to the maximum width and length

Other dimensions (also thickness), colours, shapes and cut-out parts on request.

The chosen damping plate should be tested by the customer on the specific application.

#### Dimensions and Capacity Chart

Material Type	W <sub>3</sub> max.* Nm/stroke	Stroke Utilization* mm	A mm	B mm	C mm	Area mm <sup>2</sup>	Density kg/m <sup>3</sup>	Return Time sec.	Weight g
SL-300-25-Dxxxx	19.5 (90.0)	6 (12)	50	50	25	2 500	800	approx. 3 (4)	approx. 50
SL-300-25-Dxxxx	50.0 (225.0)	6 (12)	70.7	70.7	25	5 000	800	approx. 3 (4)	approx. 100
SL-300-25-Dxxxx	150.0	6 (12)	100	100	25	10 000	800	approx. 3 (4)	approx. 200

\* Energy absorption and stroke utilization as well as the below illustrated dynamic curve progression refer to a calculated free falling mass with an impact velocity of 1 m/s. For differing application data, these values can only be used as a reference. The energy absorption depends on the individual impact surface and stroke utilization. The longer the load duration the more the reduction in energy absorption (material fatigue).

SL set 1.6 includes the 3 above mentioned sample plates. For other dimensions see page 20.

#### Damping Characteristics SL-300-25

Force-Stroke static, Stroke Utilization 6 mm, 25%

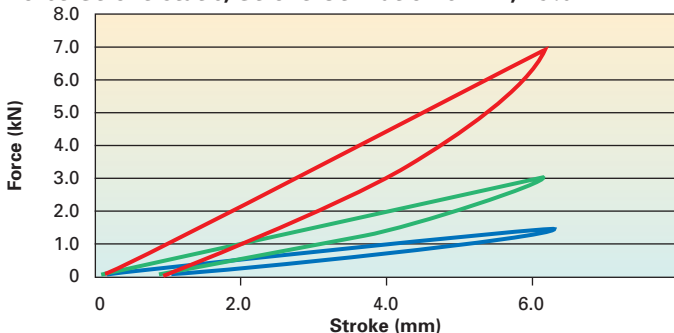

Force-Stroke dynamic, Stroke Utilization 6 mm, 25%

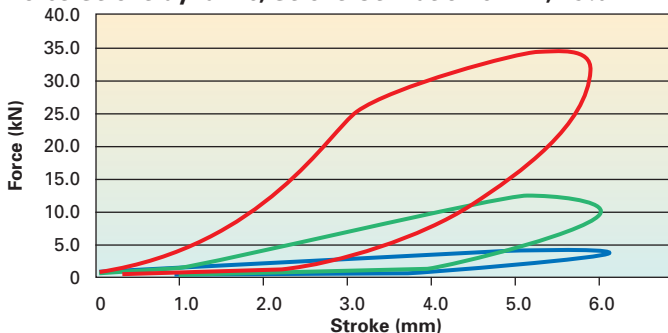

Force-Stroke static, Stroke Utilization 12 mm, 50%

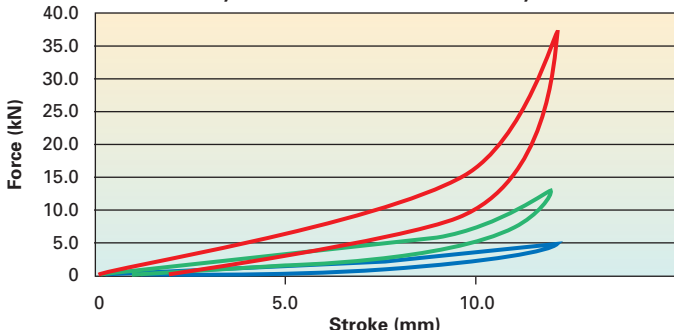

Force-Stroke dynamic, Stroke Utilization 12 mm, 50%

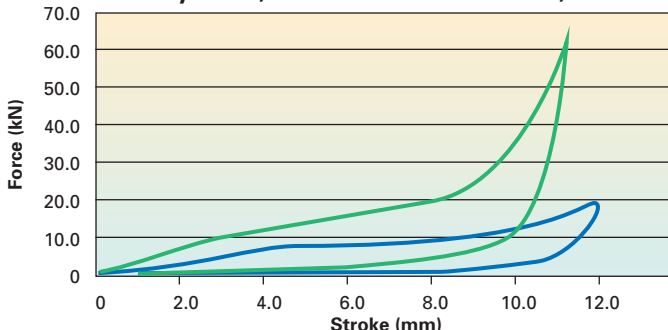

Load data: static, between two level plates,  
 Deformation velocity 1% of the plate thickness / sec.

— Area 10 000 mm<sup>2</sup>  
 — Area 5 000 mm<sup>2</sup>  
 — Area 2 500 mm<sup>2</sup>

Load data: dynamic, free-falling mass,  
 Impact velocity about 1 m/s.

Machines generate vibrations which are transmitted to the surroundings. They can influence the manufacturing process of other machines and thereby the quality of the products.

Vibrations disrupt the location and the environment and cause damage to buildings. SLAB Polyurethane elastomer is a material that effectively reduces vibration and structure-borne noise.

Depending on the requirements, SLABs are available in different densities, thicknesses and dimensions.

**SLAB damping plates are used to insulate vibrations for:**

- Machine tools
- Textile machinery
- Air conditioning and ventilating machines
- Crane rails
- Hydraulic crushers
- Presses / stamping machines etc.

Potential for direct bearing support on SLAB damping plates:

Full surface mount

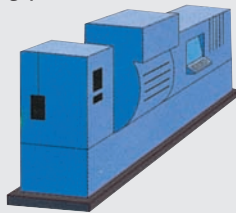

Strip bearings

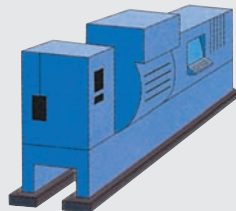

Discrete bearings

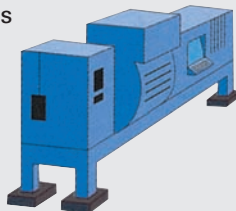

#### Even load distribution of vibration damping elements are illustrated using the example of a combustion engine

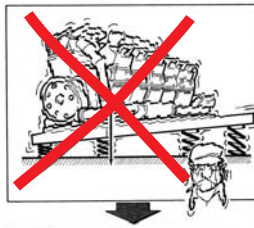

Pay attention to center of gravity!

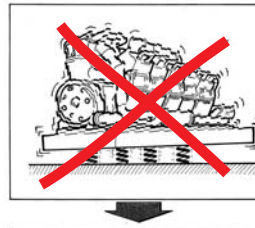

Maximize the bearing's torsional stiffness!

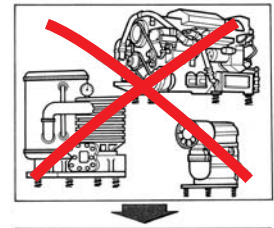

Merging of assembly groups (combined elastic bearing)

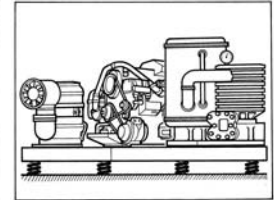
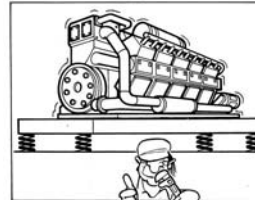
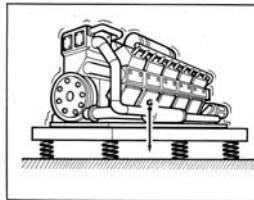

#### Mounting of individual equipment components illustrated using the example of a pump

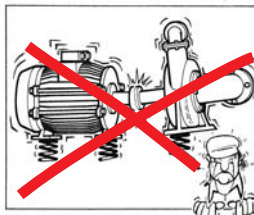

Pay attention to separate flexible mounts of connected equipment components!

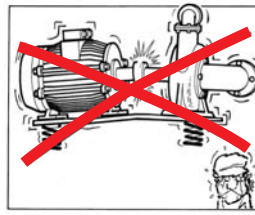

Pay attention to flexible base plates or machine frames!

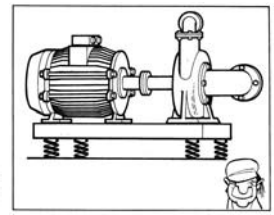

Use large flex resistant base plates or machine frames!

#### Full surface mounted eccentric press

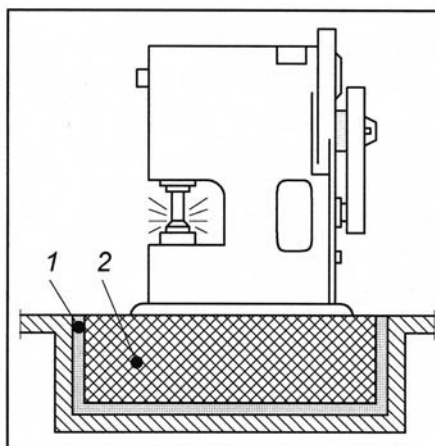

- sufficient base size
- modeling
- assure vibration insulation
- static view: center of gravity, deflection
- maximize torsional stiffness
- dynamic view: forces, torques, amplitude

1 Vibration damping  
2 Concrete base

Source: SUVA,  
Elastic Bearing of Machines

SLAB damping plates of the SL-450, SL-600 and SL-720 are universally applicable elastic PUR materials that are manufactured according to a patented formula that are used throughout industry.

The standard densities of 450 kg/m<sup>3</sup>, 600 kg/m<sup>3</sup> and 720 kg/m<sup>3</sup> serve as vibration insulation in a wide variety of applications. For specific applications, special designs with specific densities can be manufactured. The static and dynamic product characteristics are precisely defined. The effectiveness of elastic suspension can be calculated in advance. The necessary parameters are shown on the checklist on page 19.

The static load capacity of standard materials are in the range of:  
 SL-450 0 to 0.15 N/mm<sup>2</sup>  
 SL-600 0 to 0.30 N/mm<sup>2</sup>  
 SL-720 0 to 0.50 N/mm<sup>2</sup>  
 and for special designs up to 0.8 N/mm<sup>2</sup>.  
 Unusual and light loads can withstand forces of 5.0 N/mm<sup>2</sup>.  
 This value can reach up to 6 N/mm<sup>2</sup> for special designs.

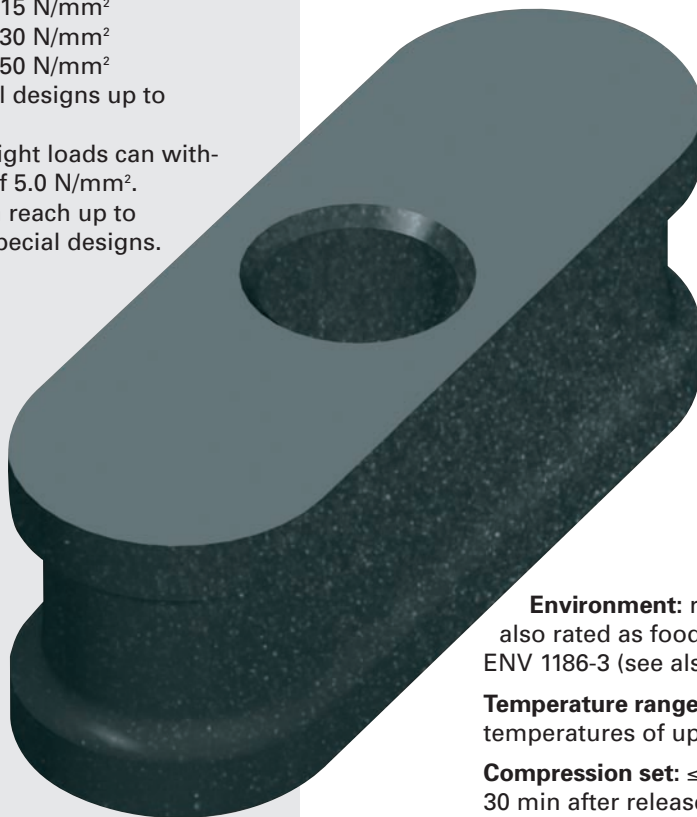
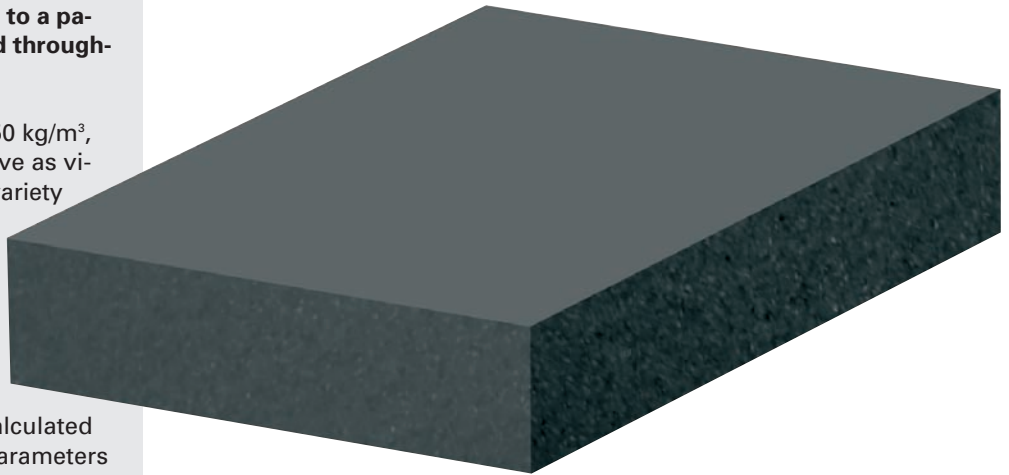

**Environment:** resistant to ozone and UV radiation, also rated as food-graded harmless, according to ENV 1186-3 (see also chemical resistance page 18)

**Temperature range:** -30°C to +70°C, short-term higher temperatures of up to 110°C possible.

**Compression set:** ≤5%, at 50% of compression, 23°C, 70 h, 30 min after release, according to EN ISO 1856

**Fire rating:** B2, normally flammable, according to DIN 4102

**Standard density:** 450 kg/m<sup>3</sup>, 600 kg/m<sup>3</sup> and 720 kg/m<sup>3</sup>, according to DIN 53420, special designs on request

**Permanent static load:** 0 to 0.15 N/mm<sup>2</sup>, 0 to 0.30 N/mm<sup>2</sup> and 0 to 0.50 N/mm<sup>2</sup>

**On request:** available with compact polyurethane wear protection, Shore hardness: 82 Shore Sh A

**Possibilities for cutting:** water jet cutting, stamping, splitting, sawing, drilling, etc.

**Mounting possibilities:** bonding (see adhesive recommendation page 17), clamping, screwing, etc..

These data are based on the current standard of knowledge. They can be taken as calculation or reference values and are subject to the usual manufacturing tolerances; subject to change.

### Ordering Example

ACE-SLAB \_\_\_\_\_  
 Material Type \_\_\_\_\_  
 Material Thickness \_\_\_\_\_  
 Dimension/Shape \_\_\_\_\_  
 (is assigned by ACE)

**SL-450-12-Fxxxx**

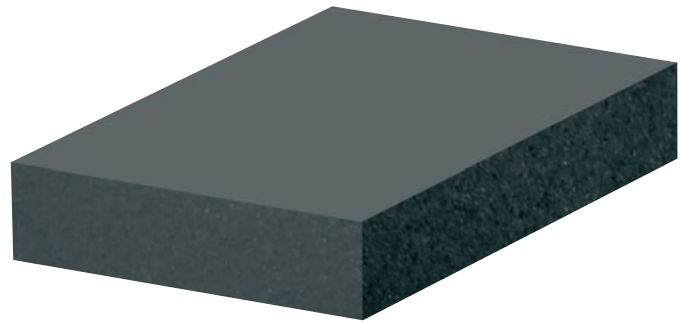

### Technical Data

**Material:** mixed cellular polyether urethane  
**Standard Colour:** black  
**Characteristics:** elastic PUR material with spring/damping characteristics  
**Delivery Form:** thickness 12 mm and 25 mm  
 rolls: 1.5 m wide, 5.0 m long, strips: up to the maximum width and length

Other dimensions (also thickness), colours, shapes and cut-out parts on request.

### Recommendation for Elastic Bearing:

Permanent Static Load	0 to 0.15 N/mm <sup>2</sup>
Application	0 to 0.25 N/mm <sup>2</sup>
Peak Loads	up to 2.0 N/mm <sup>2</sup>

### Physical Characteristics

	Value	Unit	Test Method	Notice
Density	450	kg/m <sup>3</sup>	EN ISO 845	
Tensile strength	1.5	N/mm <sup>2</sup>	following EN ISO 527-3/5/100	minimum value
Elongation at break	300	%	following EN ISO 527-3/5/100	minimum value
Compression set	3.8	%	EN ISO 1856	50 %, 23 °C, 70 h, 30 min after release
Mechanical loss factor	0.17		following DIN 53513	load and frequency dependent
Static modulus of rigidity	0.48	N/mm <sup>2</sup>	following DIN 53513	load dependent
Dynamic modulus of rigidity	0.76	N/mm <sup>2</sup>	following DIN 53513	load and frequency dependent

### Characteristics

#### Spring Characteristics SL-450 <sup>1)</sup>

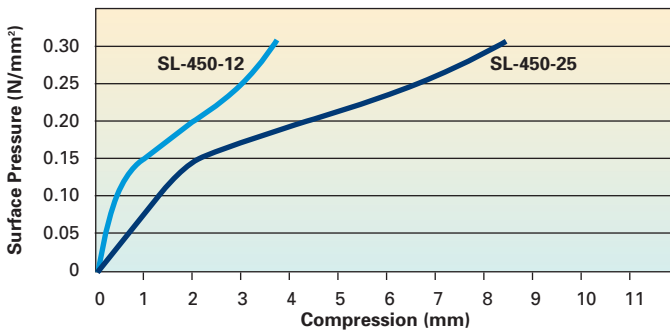

#### Elasticity Module SL-450 <sup>2)</sup>

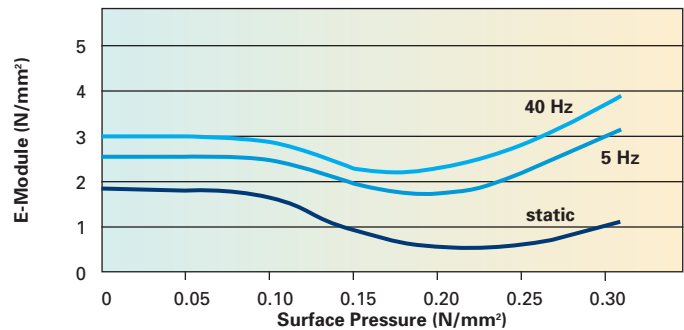

#### Natural Frequency SL-450 <sup>3)</sup>

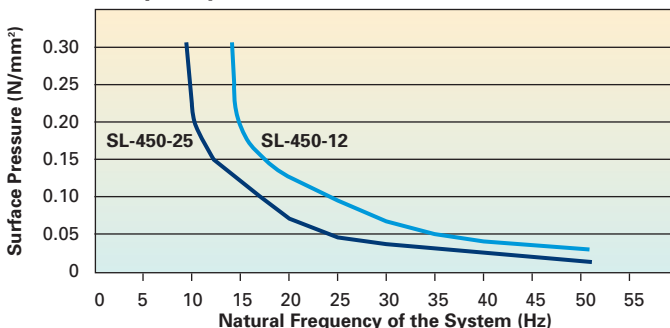

- 1) Samples: 300 x 300 mm, initially compressed between level plates, released and then tested.  
Deformation: 1% of thickness/s, room temperature
- 2) Static E-Module: tangent module from spring characteristics  
Dynamic E-Module: Samples 300 x 300 x 25 mm  
Sinusoidal excitation with amplitude 0.25 mm
- 3) Lowest frequency of a single mass pendulum with an elastic bearing of SL-450

### Ordering Example

ACE-SLAB \_\_\_\_\_  
 Material Type \_\_\_\_\_  
 Material Thickness \_\_\_\_\_  
 Dimension/Shape \_\_\_\_\_  
 (is assigned by ACE)

SL-600-12-Fxxxx

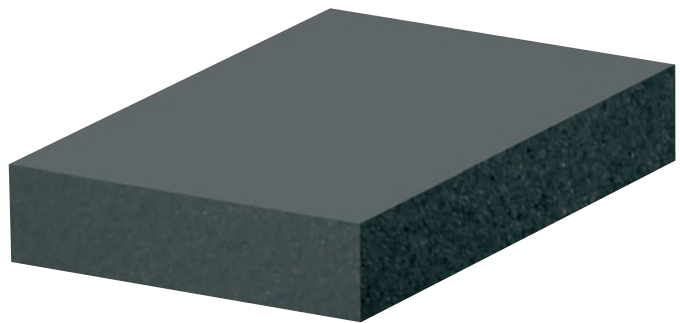

### Technical Data

**Material:** mixed cellular polyether urethane  
**Standard Colour:** black  
**Characteristics:** elastic PUR material with spring/damping characteristics  
**Delivery Form:** thickness 12 mm and 25 mm  
 rolls: 1.5 m wide, 5.0 m long, strips: up to the maximum width and length

Other dimensions (also thickness), colours, shapes and cut-out parts on request.

### Recommendation for Elastic Bearing:

Permanent Static Load	0 to 0.30 N/mm <sup>2</sup>
Application	0 to 0.45 N/mm <sup>2</sup>
Peak Loads	up to 3.0 N/mm <sup>2</sup>

### Physical Characteristics

	Value	Unit	Test Method	Notice
Density	600	kg/m <sup>3</sup>	EN ISO 845	
Tensile strength	2.0	N/mm <sup>2</sup>	following EN ISO 527-3/5/100	minimum value
Elongation at break	300	%	following EN ISO 527-3/5/100	minimum value
Compression set	5.0	%	EN ISO 1856	50%, 23 °C, 70 h, 30 min after release
Mechanical loss factor	0.12		following DIN 53513	load and frequency dependent
Static modulus of rigidity	0.8	N/mm <sup>2</sup>	following DIN 53513	load dependent
Dynamic modulus of rigidity	1.2	N/mm <sup>2</sup>	following DIN 53513	load and frequency dependent

### Characteristics

#### Spring Characteristics SL-600 <sup>1)</sup>

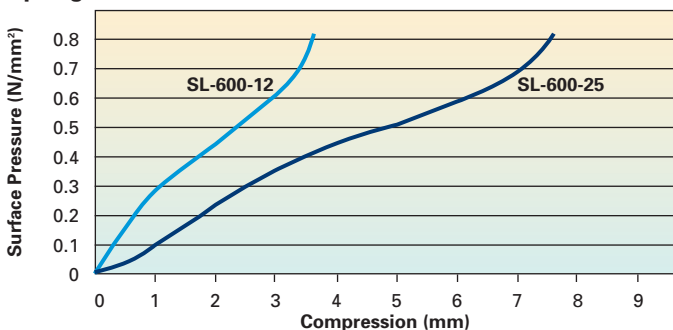

#### Elasticity Module SL-600 <sup>2)</sup>

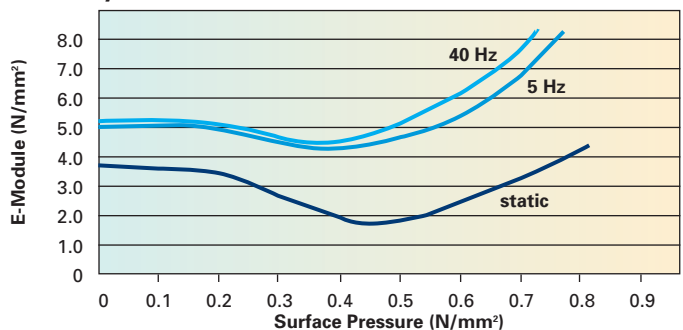

#### Natural Frequency SL-600 <sup>3)</sup>

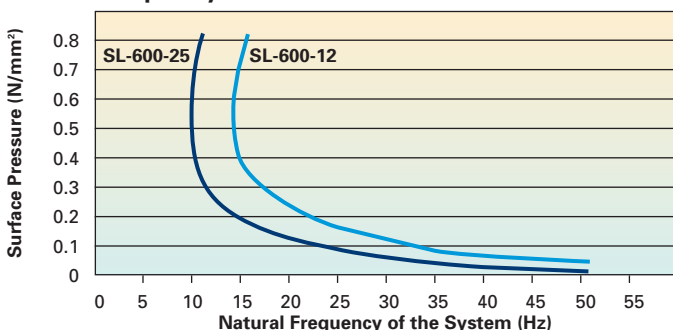

- 1) Samples: 300 x 300 mm, initially compressed between level plates, released and then tested.  
Deformation: 1% of thickness/s, room temperature
- 2) Static E-Module: tangent module from spring characteristics  
Dynamic E-Module: Samples 300 x 300 x 25 mm  
Sinusoidal excitation with amplitude 0.25 mm
- 3) Lowest frequency of a single mass pendulum with an elastic bearing of SL-600

### Ordering Example

ACE-SLAB \_\_\_\_\_  
 Material Type \_\_\_\_\_  
 Material Thickness \_\_\_\_\_  
 Dimension/Shape \_\_\_\_\_  
 (is assigned by ACE)

SL-720-12-Fxxxx

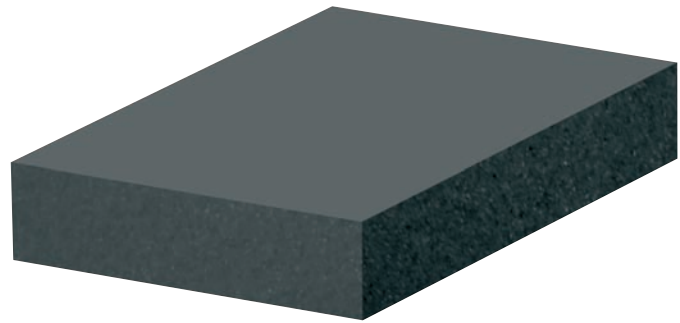

### Technical Data

**Material:** mixed cellular polyether urethane  
**Standard Colour:** black  
**Characteristics:** elastic PUR material with spring/damping characteristics  
**Delivery Form:** thickness 12 mm and 25 mm  
 rolls: 1.5 m wide, 5.0 m long, strips: up to the maximum width and length

Other dimensions (also thickness), colours, shapes and cut-out parts on request.

### Recommendation for Elastic Bearing:

Permanent Static Load	0 to 0.50 N/mm <sup>2</sup>
Application	0 to 0.75 N/mm <sup>2</sup>
Peak Loads	up to 5.0 N/mm <sup>2</sup>

### Physical Characteristics

	Value	Unit	Test Method	Notice
Density	720	kg/m <sup>3</sup>	EN ISO 845	
Tensile strength	3.0	N/mm <sup>2</sup>	following EN ISO 527-3/5/100	minimum value
Elongation at break	300	%	following EN ISO 527-3/5/100	minimum value
Compression set	5.0	%	EN ISO 1856	50 %, 23 °C, 70 h, 30 min after release
Mechanical loss factor	0.12		following DIN 53513	load and frequency dependent
Static modulus of rigidity	1.0	N/mm <sup>2</sup>	following DIN 53513	load dependent
Dynamic modulus of rigidity	1.5	N/mm <sup>2</sup>	following DIN 53513	load and frequency dependent

### Characteristics

#### Spring Characteristics SL-720 <sup>1)</sup>

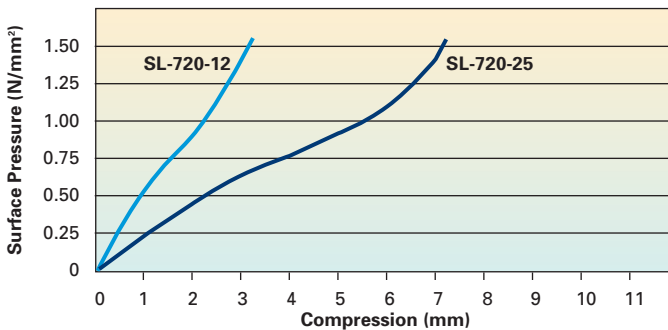

#### Elasticity Module SL-720 <sup>2)</sup>

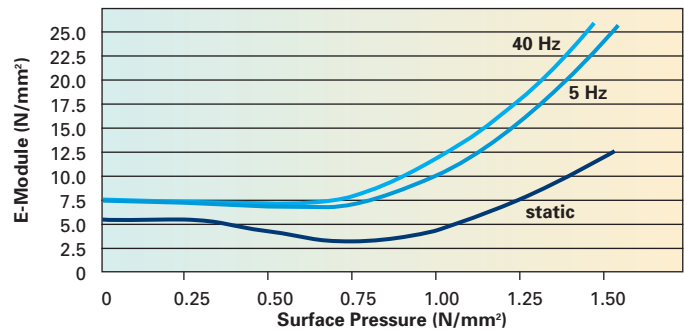

#### Natural Frequency SL-720 <sup>3)</sup>

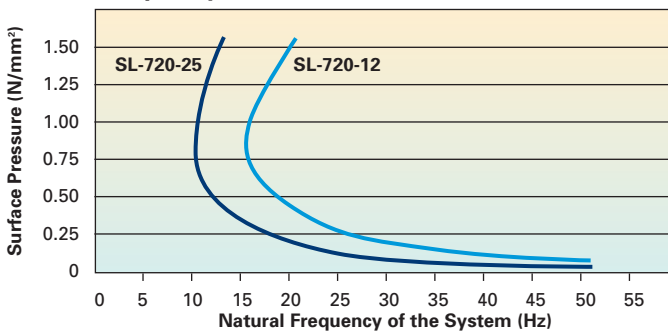

- 1) Samples: 300 x 300 mm, initially compressed between level plates, released and then tested.  
Deformation: 1% of thickness/s, room temperature
- 2) Static E-Module: tangent module from spring characteristics  
Dynamic E-Module: Samples 300 x 300 x 25 mm  
Sinusoidal excitation with amplitude 0.25 mm
- 3) Lowest frequency of a single mass pendulum with an elastic bearing of SL-720

### Bonding of Polyurethane (PUR) Elastomers

Cellular and compact parts of polyurethane (PUR) elastomers Slab damping plates can be bonded according to the following recommendations. If treatment instructions are followed, the strengths of the bonded joint can be equivalent to the elastomer material itself.

#### 1. General Information

To achieve the required bonding strength it is necessary to ensure the correct adhesive is chosen for each individual application.

**Contact Bonding Material:** thin adhesive film, with little filling of the gaps. Correcting or moving of the areas covered with bonding material is no longer possible after the first contact is made (contact effect).

Once a bonding is separated, the bonding process must be renewed. Please note that creases, ripples or blisters cannot be straightened once the contact is made.

**Hardening Bonding Material:** (As thin as possible) the film of glue fills the joint. The gluing can be done after the edges are brought together.

#### 2. Preparation

The preparation of bonding surfaces is of decisive importance for the bonding strength. The surfaces must be adapted to each other and available in plain, clean form.

**Careful removal of:** adhesive remnants, oil, fat, separating agents, dirt, dust, scales, molding layers, protective coating, finish, paint, sweat etc.

**Mechanical Support:** stripping, brushing, scraping, grinding, sandblasting

**Chemical Support:** degreasing (washing off with grease remover), etching, priming; pay attention to chemical resistancy on page 18!

In general, SLAB damping plates in sheet form can be bonded without pretreatment. Molded parts, with or without special skin, have to be cleaned from left-over separating agents, if necessary by grinding. When bonding with other materials like plastic, wood, metal or concrete, mechanical and/or chemical additives have to be used.

The adhesive has to be prepared according to the formula, observing the manufacturer's recommendations. The adhesive film is also to be carefully applied pursuant to these details. (Tools: brush, spatula, adhesive spreader, airless spray gun).

**Contact Bonding Material:** Apply the non-gap-filling adhesive film to both bonding surfaces – the thinner, the better. To close the pores of low density materials, two layers may be necessary.

**Hardening Bonding Material:** Apply evenly. Possible irregularities can be compensated by the film thickness.

#### 3. Bonding

When using contact bonding material, the flash off time has to be kept in mind. Especially, with systems containing water instead of usual solvents, the adhesive film must be as dry as possible in order to pass the 'finger test' – no marks appear when touching the adhesive surface. When using hardening bonding material, the parts have to be joined immediately after applying the bonding material.

#### 4. Pressing

**Contact Bonding Material:** contact pressure up to 0.5 N/mm<sup>2</sup>  
**Hardening Bonding Material:** fix firmly

It is important to carefully follow the manufacturer's instructions with regard to processing temperature, hardening time and earliest possible loading.

#### 5. Selection of Approved Bonding Materials

Because of the variety of materials that can be bonded together as well as numerous suitable bonding materials, the following list can only give information for certain combinations. For specific problems, please contact our applications technical department or get in touch with an adhesive producer you are familiar with.

##### 5.1. Bonding of SLAB Damping Plates – to each other: (also SLAB damping plates on wood)

Ibola R 125 (H 2-K)	Co. Fuller Munich (Wels - Austria)
Ibola R 101 (H 2-K)	Co. Fuller Munich (Wels - Austria)
Makroplast UK 8202 (H 2-K)	Co. Henkel KGA Düsseldorf
UR 7225 B (H1-K)	Co. Henkel KGA Düsseldorf
Ultraflex 55 (K)	Co. Fuller München (Wels - Austria)
Icema R 145/44 (H 1-K)	Co. Fuller München (Wels - Austria)
Technicoll 8500 (K)	Co. Beiersdorf AG Hamburg

K = contact bonding material  
 H 1-K = one-component reactive adhesive  
 H 2-K = two-component adhesive

##### 5.2. SLAB Damping Plates with other Materials:

###### a) Concrete and other mineral surfaces

The adhesives mentioned under point '5.1' are suitable for these applications.

###### b) Metallic surfaces

In most cases, a mechanical and chemical pre-treatment is necessary. The following primers have proven to be suitable during our tests for the materials:

Isarplast L440 VS (aluminium and iron)	Co. Fuller Munich/Wels
Isarplast L744 (special steel)	Co. Fuller Munich/Wels
Sika Metallprimer (aluminium and iron)	Co. Sika Gmbh Hamburg
Thixon 422 (aluminium and iron)	Co. Nordmann, Rassmann Hamburg

The actual adhesion can be affected with the adhesives mentioned under '5.1'. For galvanized steel sheets no primer is needed if the following adhesive is used:

ICEMA R 147P	(Co. Fuller Munich/Wels)
--------------	--------------------------

###### c) Plastics

Because of the wide variety of plastics, no general adhesive recommendation is possible. For many plastics, adhesives based on  $\alpha$ -cyanoacrylates have proven to be suitable. Chemical treatment with primers also allows the bonding of polyolefines (e.g. polyethylene) with SLAB damping plates.

#### Test (following DIN 53428)

Exposure time of the medium: 6 weeks at room temperature, but for concentrated acids and bases as well as solvents: 7 days at room temperature

#### Evaluation Criteria

Changing of tensile strength and elongation of break (dry samples), change in volume

#### Evaluation Standard

- 1 Excellent resistance, change in characteristics <10%
- 2 Good resistance, change in characteristics between 10% and 20%
- 3 Conditional resistance, change in characteristics partly above 20%
- 4 Not resistant, change in characteristics all above 20%

All Information is based on our current knowledge and experiences. We reserve the rights for changes towards product refinement.

\* The resistance towards acids and bases depends on the concentration.

#### Water/watery solutions

	SL-030	SL-450
	SL-100	SL-600
	SL-300	SL-720
Water	1	1
Iron(III) chloride 10%	1	1
Sodium carbonate 10%	1	1
Sodium chlorate 10%	1	1
Sodium chloride 10%	1	1
Sodium hydrogencarbonate 10%	1	1
Sodium nitrate 10%	1	1
Herbicides (div.)	1	1
Tensides (div.)	1	1
Hydrogen peroxide 3%	1	1
Laitance	1	1

#### Oils and Greases

	SL-030	SL-450
	SL-100	SL-600
	SL-300	SL-720
ASTM Oil No. 1	1	1
ASTM Oil No. 3	1	1
Laitance	2	2
Hydraulic oils	depends on consistency/additives	
Motor oil	1	1
Turpentine oil	3	3
Formwork oil	1	1
Silicone oil	1	1
Cooking oil	1	1
High performance grease	1-2	1-2
Railroad switch lubricant	1-2	1-2

#### Oils and Bases\*

	SL-030	SL-450
	SL-100	SL-600
	SL-300	SL-720
Formic acid	4	4
Acetic acid	3	3
Phosphoric acid	2	2
Nitric acid	4	4
Hydrochloric acid	3	3
Sulphuric acid	3	3
Ammonia solution	3	3
Caustic potash solution	2	2
Caustic soda solution	2	2

#### Solvents

	SL-030	SL-450
	SL-100	SL-600
	SL-300	SL-720
Acetone	4	4
Ethyl acetate	4	4
Diesel/Fuel oil	2	2
Carburetor fuel/benzine	3	3
Glycerin	1	1
Glycols	1-2	1-2
Cleaning solvents/hexane	1	1
Methanol	3	3
Thinner	4	4
Aromatic hydrocarbons	4	4

#### Other Factors

	SL-030	SL-450
	SL-100	SL-600
	SL-300	SL-720
Hydrolysis	1	1
Ozone	1	1
UV radiation and weathering	1-2	1-2
Biological resistance	1	1



In order to process your inquiry quickly, we need the following information:

### 1. Description of Application

- a) Description of your application in key words – the kind of machine/device that needs insulation  
.....
- b) Machine design (possibly data sheet with information about loads, installation (drawing))  
.....
- c) Static and dynamic machine loads (do these operate off-center?)  
.....
- d) Mounting with foundation:  
What dimensions are available? Is sideways support necessary? length \_\_\_\_\_ mm, width \_\_\_\_\_ mm, height \_\_\_\_\_ mm  
yes  no
- e) Mounting without foundation:  
Which machine mount is present (machine stands, U-profile mount, etc.) contact area \_\_\_\_\_ mm  
number of contact areas \_\_\_\_\_
- f) Environmental requirements air humidity \_\_\_\_\_ %, temperature \_\_\_\_\_ °C,  
liquids/foreign matter \_\_\_\_\_
- g) Required product life \_\_\_\_\_
- h) Safety element: yes  no

### 2. Physical Dimensions

- a) Measurements and weight of the machine mass \_\_\_\_\_ kg
- b) Center of gravity concentric  excentric  (sketch)
- c) Operation of the machine, e.g., frequencies or revolutions per minute (exciter frequency) \_\_\_\_\_ Hz \_\_\_\_\_ 1/s
- d) Available area for set up length \_\_\_\_\_ mm, width \_\_\_\_\_ mm,  
diameter \_\_\_\_\_ mm, number of load points \_\_\_\_\_
- e) Maximum mounting height of bearing height \_\_\_\_\_ mm, tolerance \_\_\_\_\_ +/- mm,
- f) Permissible deflection \_\_\_\_\_ mm, permissible amplitudes \_\_\_\_\_ mm,
- g) Is operational reliability/product life of the machine by the elastic bearing? yes  no

Special requirements: \_\_\_\_\_ Quantity/year: \_\_\_\_\_  
 \_\_\_\_\_ Machine type: \_\_\_\_\_  
 \_\_\_\_\_

#### Sender:

Company \_\_\_\_\_ Department \_\_\_\_\_  
 Address \_\_\_\_\_ Name/Pos. \_\_\_\_\_  
 \_\_\_\_\_ Telephone \_\_\_\_\_ Fax \_\_\_\_\_  
 Internet \_\_\_\_\_ E-Mail \_\_\_\_\_

Please copy, fill out and fax with sketch to: Fax +49-(0)2173-9226-89

Issue 4.2007 Specifications subject to change

## Damping Plates for Shock Absorption

### Set "Sizes"

comprising 1 model, 1 type of thickness, 3 sizes = 3 sample plates

Part Number	Contents
SL-SET-1.1	SL-030-12 (dimensions 50 x 50 mm, 70.7 x 70.7 mm, 100 x 100 mm)
SL-SET-1.2	SL-030-25 (dimensions 50 x 50 mm, 70.7 x 70.7 mm, 100 x 100 mm)
SL-SET-1.3	SL-100-12 (dimensions 50 x 50 mm, 70.7 x 70.7 mm, 100 x 100 mm)
SL-SET-1.4	SL-100-25 (dimensions 50 x 50 mm, 70.7 x 70.7 mm, 100 x 100 mm)
SL-SET-1.5	SL-300-12 (dimensions 50 x 50 mm, 70.7 x 70.7 mm, 100 x 100 mm)
SL-SET-1.6	SL-300-25 (dimensions 50 x 50 mm, 70.7 x 70.7 mm, 100 x 100 mm)

### Set "Models"

comprising 3 models, 1 type of thickness, 1 size = 3 sample plates

Part Number	Contents
SL-SET-2.1	SL-030-12, SL-100-12, SL-300-12 (dimensions 50 x 50 mm)
SL-SET-2.2	SL-030-25, SL-100-25, SL-300-25 (dimensions 50 x 50 mm)
SL-SET-2.3	SL-030-12, SL-100-12, SL-300-12 (dimensions 70.7 x 70.7 mm)
SL-SET-2.4	SL-030-25, SL-100-25, SL-300-25 (dimensions 70.7 x 70.7 mm)
SL-SET-2.5	SL-030-12, SL-100-12, SL-300-12 (dimensions 100 x 100 mm)
SL-SET-2.6	SL-030-25, SL-100-25, SL-300-25 (dimensions 100 x 100 mm)

### Set "Thickness"

comprising 1 model, 2 types of thickness, 1 size = 2 sample plates

Part Number	Contents
SL-SET-3.1	SL-030-12, SL-030-25 (dimensions 50 x 50 mm)
SL-SET-3.2	SL-030-12, SL-030-25 (dimensions 70.7 x 70.7 mm)
SL-SET-3.3	SL-030-12, SL-030-25 (dimensions 100 x 100 mm)
SL-SET-3.4	SL-100-12, SL-100-25 (dimensions 50 x 50 mm)
SL-SET-3.5	SL-100-12, SL-100-25 (dimensions 70.7 x 70.7 mm)
SL-SET-3.6	SL-100-12, SL-100-25 (dimensions 100 x 100 mm)
SL-SET-3.7	SL-300-12, SL-300-25 (dimensions 50 x 50 mm)
SL-SET-3.8	SL-300-12, SL-300-25 (dimensions 70.7 x 70.7 mm)
SL-SET-3.9	SL-300-12, SL-300-25 (dimensions 100 x 100 mm)

### Set "Complete"

comprising 3 models, 2 types of thickness, 3 sizes = 18 sample plates

Part Number	Contents
SL-SET-4	SL-030-12, SL-030-25, SL-100-12, SL-100-25, SL-300-12, SL-300-25 (dimensions 50 x 50 mm, 70.7 x 70.7 mm, 100 x 100 mm)

### Sample Plates

Part Number	Dimensions and Type
SL-030-12-D-MP4	220 x 150 x 12 mm
SL-030-12-D-MP4-V+K	220 x 150 x 12 mm + layer for wear protection 2 mm, self-adhesive on one side
SL-030-25-D-MP4	220 x 150 x 25 mm
SL-100-12-D-MP4	220 x 150 x 12 mm
SL-100-12-D-MP4-V+K	220 x 150 x 12 mm + layer for wear protection 2 mm, self-adhesive on one side
SL-100-25-D-MP4	220 x 150 x 25 mm
SL-300-12-D-MP4	220 x 150 x 12 mm
SL-300-12-D-MP4-V+K	220 x 150 x 12 mm + layer for wear protection 2 mm, self-adhesive on one side
SL-300-25-D-MP4	220 x 150 x 25 mm
SL-030-12-D-MP5	1500 x 800 x 12 mm
SL-030-25-D-MP5	1500 x 800 x 25 mm
SL-100-12-D-MP5	1500 x 800 x 12 mm
SL-100-25-D-MP5	1500 x 800 x 25 mm
SL-300-12-D-MP5	1500 x 800 x 12 mm
SL-300-25-D-MP5	1500 x 800 x 25 mm

## Damping Plates for Vibration Damping

### Sample Plates

Part Number	Dimensions
SL-450-12-F-MP4	220 x 150 x 12 mm
SL-600-12-F-MP4	220 x 150 x 12 mm
SL-720-12-F-MP4	220 x 150 x 12 mm

## FAX REQUEST

Company

Name

Department/Position

Street/PO Box

Postcode/City

Country

Telephone/Fax

E-Mail

Internet



### YES! We are interested in:

- further copy of the new ACE Catalogue.
- the new ACE CAD-Library with Selection programme on CD-Rom. 2D- and 3D-Version (standard formats).
- Training at our site.
- Technical assistance at our site.

**NEW: CAD-library and selection programme online**

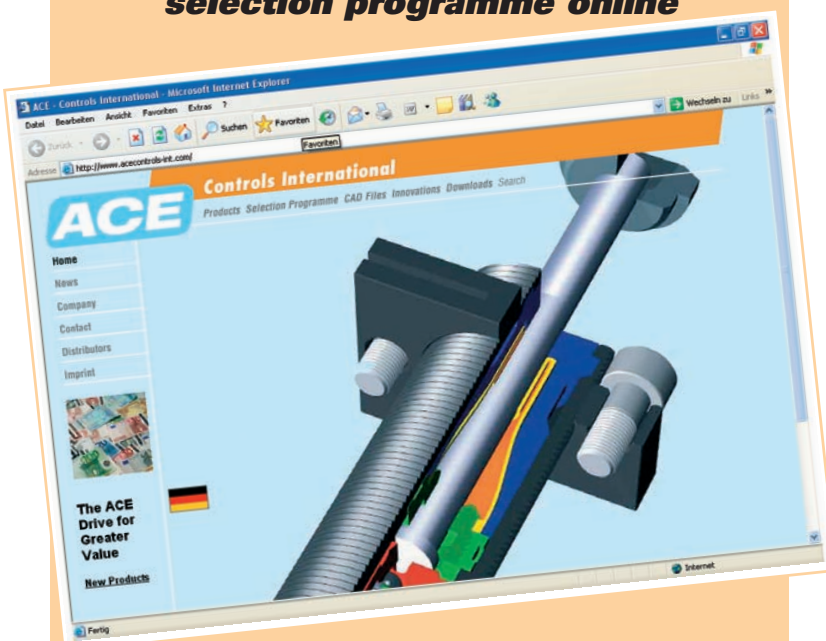

**Update for your earlier version via internet!  
[www.acecontrols-int.com](http://www.acecontrols-int.com)**

# FAX to **+49 - 2173 - 9226 - 89**

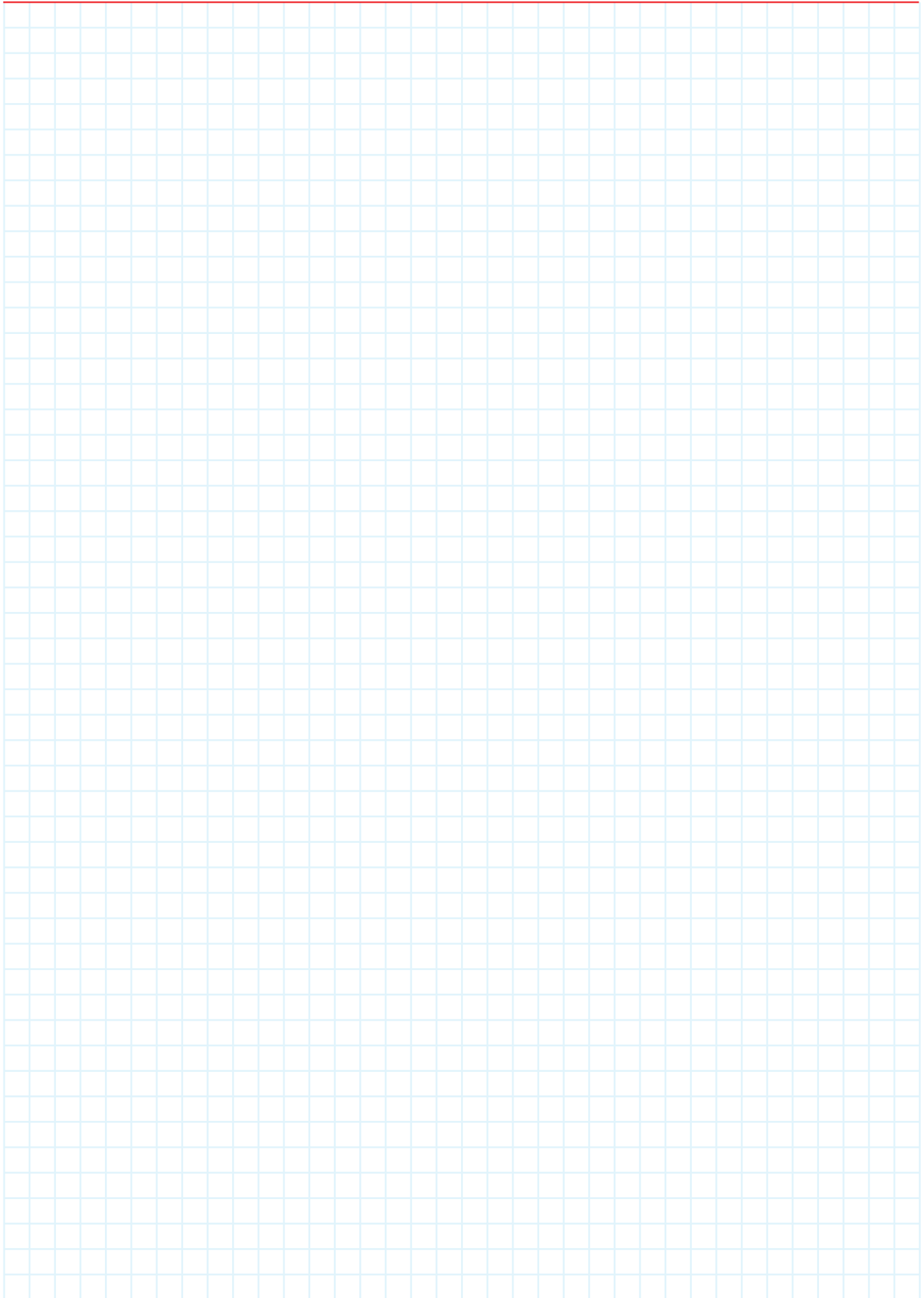
A large, empty grid of light blue lines on a white background, intended for taking notes. The grid consists of approximately 30 columns and 40 rows of small squares.

A large, empty grid of light blue lines on a white background, intended for taking notes. The grid covers most of the page area below the header.

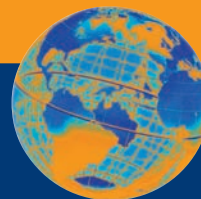

**ARGENTINA**  
CAMOZZI NEUMATICA S.A.  
Prof. Dr. Pedro Chutro 3048  
1437 Buenos Aires  
Argentina  
Tel.: +54-11 49110816  
Fax: +54-11 49124191



**AUSTRALIA**  
IMI NORGREN LTD.  
33 South Corporate Av.  
Rowville, Victoria 3178, Australia  
Tel.: +61-3 9213 0800  
Fax: +61-3 9213 0898



**AUSTRIA**  
ACE STOSSDÄMPFER GMBH  
Herzogstraße 26-28, 40764 Langenfeld  
Germany  
Tel.: +49-2173-9226-70  
Fax: +49-2173-9226-29  
(Vertriebspartner auf Anfrage)



**BELGIUM**  
ACE STOSSDÄMPFER GMBH  
Herzogstraße 26-28, 40764 Langenfeld  
Germany  
Tel.: +49-2173-9226-70  
Fax: +49-2173-9226-29  
(Vertriebspartner auf Anfrage)



**BRAZIL**  
OBR EQUIPAMENTOS  
INDUSTRIAIS LTDA.  
Rua Piratuba, 1573, Bom Retiro  
Joinville-SC (South Brazil)  
CEP 89.222-365  
Brazil  
Tel.: +55-0800 704 3698 / 47 3435 44 64  
Fax: +55-47 3425 90 30



**CANADA**  
COWPER LTD.  
677 7th Avenue, Lachine  
Quebec H8S 3A1  
Tel.: +1-514-637-6746  
Fax: +1-514-637-5055



**CHILE**  
TAYLOR AUTOMATIZACION S. A.  
A.V. Vicuna Mackenna, # 1589 Santiago  
Chile  
Tel.: +56-25 55 15 16  
Fax: +56-25 44 19 65



**CROATIA AND BOSNIA**  
BIBUS ZAGREB D.O.O.  
Anina 91, 10000 Zagreb  
Croatia  
Tel.: +385-1 3818 006  
Fax: +385-1 3818 005



**CZECH REPUBLIC**  
BIBUS S.R.O.  
Videnska 125, 639 27 Brno  
Czech Republic  
Tel.: +420-547 125 300  
Fax: +420-547 125 310



**DENMARK**  
AVN PNEUMATIK A-S  
Dalager 1, 2605 Broendby  
Denmark  
Tel.: +45-70 20 04 11  
Fax: +45-43 24 55 00



**FINLAND**  
NESTEPAINEN OY  
Makituvantie 11, 01510 Vantaa  
Finland  
Tel.: +358-20 765 165  
Fax: +358-20 765 7666



**FRANCE**  
BIBUS FRANCE  
Zl du Chapotin, 69970 Chaponnay  
France  
Tel.: +33-4 78 96 80 00  
Fax: +33-4 78 96 80 01



**GREAT BRITAIN**  
ACE CONTROLS INTERNATIONAL  
Belvedere Road, Newton-Le-Willows  
Merseyside, WA12 0JJ, U.K.  
Tel.: +44-19 25 22 71 71  
Fax: +44-19 25 22 93 23



**GREECE**  
PNEUMATEC  
INDUSTRIAL AUTOMATION SYSTEMS  
91 Spirou Patsi Street,  
Athens 11855  
Greece  
Tel.: +302-1 03412101 / 3413930  
Fax: +302-1 03413930



**HONGKONG**  
IMI NORGREN LTD.  
6th Floor, Benson Tower  
74 Hung To Road, Kwun Tong  
Kowloon, Hongkong  
Tel.: +852-24 92 76 08  
Fax: +852-24 92 76 78



UNIVERSE TECHNOLOGY LTD.  
Flat E, 17/F, Mai On Ind. Bldg.  
17 Kukng Yip St.  
Kwi Chung, Hongkong  
Tel.: +852-26 19 00 13  
Fax: +852-26 19 02 73



**HUNGARY**  
BIBUS KFT.  
1103 Budapest, Ujhegyi ut 2, Hungary  
Tel.: +36-1265 27 33  
Fax: +36-1264 89 00



**INDIA**  
MACO CORPORATION (INDIA)  
PVT. LTD.  
2/5 Sarat Bose Road,  
"Sukh Sagar" 7th Floor, 7A,  
Kolkata - 700020  
Calcutta, India  
Tel.: +91-33 24 75 83 71 / 85 00 / 24 54 32 81  
Fax: +91-33 24 54 32 69



**IRELAND**  
IRISH PNEUMATIC  
SERVICES LTD.  
Unit 2014, City West Business Campus  
Saggart, Co. Dublin, Ireland  
Tel.: +353-14 66 02 00  
Fax: +353-14 66 01 58



**ISRAEL**  
ILAN & GAVISH  
AUTOMATION SERVICE LTD.  
24, Shenkar Street,  
Qiryat-arie 49513  
PO Box 10118, Petha-Tiqva 49001  
Israel  
Tel.: +972-39 22 18 24  
Fax: +972-39 24 07 61



**ITALY**  
R.T.I. S.R.L.  
Via Chambery 93/107V  
10142 Torino, Italy  
Tel.: +39-011-70 00 53 / 70 02 32  
Fax: +39-011-70 01 41



**JAPAN**  
ACE CONTROLS JAPAN L.L.C.  
Room 31 Tanaka Bldg.,  
2-9-6 Kanda-Tacho,  
Chiyoda-Ku, Tokyo 101-0046, Japan  
Tel.: +81-3 52 97 25 10  
Fax: +81-3 52 97 25 17



**KOREA**  
SEOWON CORPORATION  
1001 Ilsan Technotown  
1141-1 Beksuk-Dong  
Gyeonggi-Do, 410-722  
South Korea  
Tel.: +82-31 906 1100  
Fax: +82-31 906 1101



**LUXEMBOURG**  
ACE STOSSDÄMPFER GMBH  
Herzogstraße 26-28, 40764 Langenfeld  
Germany  
Tel.: +49-2173-9226-70  
Fax: +49-2173-9226-29  
(Vertriebspartner auf Anfrage)



**MALAYSIA**  
HOERBIGER-ORIGA SDN BHD  
10 & 12, Lorong IKS Juru 3,  
Juru, 14100 Simpang Ampat  
Penang, Malaysia  
Tel.: +60-(0)4 508 1011  
Fax: +60-(0)4 508 2122



**MEXICO**  
KOPAR S.A. DE C.V.  
Tomas Alva Edison 3116  
Fraccionamiento Industrial  
Monterrey, N.L. 64299 Mexico  
Tel.: +52-81 1257-5000  
Fax: +52-81 8331-4031



**NETHERLANDS**  
ACE STOSSDÄMPFER GMBH  
Herzogstraße 26-28, 40764 Langenfeld  
Germany  
Tel.: +49-2173-9226-70  
Fax: +49-2173-9226-29  
(Vertriebspartner auf Anfrage)



**NEW ZEALAND**  
IMI NORGREN (N.Z.) LTD.  
3-5 Walls Road  
PO Box 12-893, Penrose, Auckland  
Tel.: +64-95 79 01 89  
Fax: +64-95 26 33 99



**NORWAY**  
OILTECH AS.  
Dynamitveien 23, Postboks 133  
1401 Ski, Norway  
Tel.: +47-64 91 11 80  
Fax: +47-64 91 11 81



**PAKISTAN**  
J.J. HYDRAULICS &  
PNEUMATICS  
Hotel Metropole Bldg.  
Room 127, 1st Floor  
Club Road, Karachi, Pakistan 75520  
Tel.: +92-2 15 66 10 63  
Fax: +92-2 15 66 10 65



**POLAND**  
BIBUS MENOS SPZ.O.O.  
ul. Tadeusza Wendy 7/9, 81-341 Gdynia  
Poland  
Tel.: +48-5 86 60 95 70  
Fax: +48-5 86 61 71 32



**PORTUGAL**  
AIRCONTROL S.A.  
Paseo Sarroeta 4, 20014 San Sebastian  
Spain  
Tel.: +34-943 44 50 80  
Fax: +34-943 44 51 53



**PUERTO RICO**  
P & C COMPANY  
PO Box 120, Canovanas, Puerto Rico 00729  
Tel.: +1787-7 68 50 33  
Fax: +1787-7 50 68 20



**ROMANIA**  
BIBUS SES S.R.L.  
Pestalozzi 22, 300155 Timisoara  
Romania  
Tel.: +40-256 200 500  
Fax: +40-256 220 666



**RUSSIA**  
BIBUS L.L.C.  
Izmailovsky prospect 2, letter A  
190005 St. Petersburg, Russia  
Tel.: +7-812 251 62 71 / 812 251 98 24  
Fax: +7-812 251 90 14



Lubninskaya street 42, office 500  
109387 Moskow, Russia  
Tel.: +7-495 748 43 57  
Fax: +7-495 748 43 57



**SINGAPORE**  
HOERBIGER-ORIGA PTE. LTD.  
Block 5012 Ang Mo Kio Avenue 5#05-01  
TECHplace II, Singapore 569876  
Tel.: +65-64 83 29 59  
Fax: +65-64 83 29 79



NORGREN PTE. LTD.  
16 Tuas Street, Singapore 638453  
Tel.: +65-68 62 18 11  
Fax: +65-68 62 19 17



**SLOVAKIA**  
BIBUS SK S.R.O.  
Priemyselna 4, 94901 Nitra, Slovakia  
Tel.: +421-37-741-2525  
Fax: +421-37-651-6701



**SLOVENIA**  
INOTEH D.O.O.  
Ruska cesta 34, 2345 Bistrica ob Dravi  
Slovenia  
Tel.: +386-02 665 1131  
Fax: +386-02 665 2081



**SOUTH AFRICA**  
ISANDO PNEUMATICS (PTY) LTD.  
1, Skietlood Street, Isando ext. 3  
PO Box 441, Isando 1600, South Africa  
Tel.: +27-11 974-5176  
Fax: +27-11 974-6137



**SPAIN**  
AIRCONTROL S.A.  
Paseo Sarroeta 4, 20014 San Sebastian  
Spain  
Tel.: +34-943 44 50 80  
Fax: +34-943 44 51 53



**SWEDEN**  
HYDNET AB  
Turebergsvagen 5, 191 47 Sollentuna  
Sweden  
Tel.: +46-8 59 470 470  
Fax: +46-8 59 470 479



**SWITZERLAND**  
BIBUS AG  
Allmendstrasse 26, 8320 Fehraltorf  
Switzerland  
Tel.: +41-44-877 50 11  
Fax: +41-44-877 58 51



**TAIWAN**  
DANYAO TRADING  
COMPANY LTD.  
7F, NO. 19, Chung-Cheng Road  
Hsin-Chuang City, 242  
Taipei County, Taiwan  
Tel.: +886-2 22 76 82 00  
Fax: +886-2 22 76 75 73



**THAILAND**  
B-TAC AUTOMATION LTD. PART.  
115 Soi Sukhumvit 62/1 Sukhumvit RD.  
Bangjak Bangkok 10260, Thailand  
Tel.: +66-2-332 5555  
Fax: +66-2-332 9988



**TURKEY**  
T.M.G. PNEUMATIC &  
HYDRAULIC LTD.  
Necatibey Cad No. 44/2  
34420 Karakoy, Turkey  
Tel.: +90-21 22 93 82 00  
Fax: +90-21 22 49 88 34



**UKRAINE**  
BIBUS UKRAINE TOV  
Mashinobudivnykiv Str., 5A  
Chabany, 08162 Kiev Region  
Ukraine  
Tel.: +380-44 545 44 04  
Fax: +380-44 545 54 83



**USA**  
ACE CONTROLS  
INTERNATIONAL INC.  
PO Box 71, Farmington  
Michigan 48024, USA  
(and in all states)  
Tel.: +1-248-476-0213  
Fax: +1-248-476-2470